

## 1 INTRODUCTION

### 1.1 FEATURES

- **Battery Fuel Gauge for 1-Series Li-Ion Applications**
- **Resides on System Main Board**
  - Works With Embedded or Removable Battery Packs
- **Works With Battery ID Resistor in Battery Pack**
- **Microcontroller Peripheral Provides:**
  - Accurate Battery Fuel Gauging
  - Internal Temperature Sensor for System Temperature Reporting
  - **Battery Low Interrupt Warning**
  - **Battery Insertion Indicator**
  - **Battery ID Detection**
  - **96 Bytes of Non-Volatile Scratch-Pad FLASH**
- **Battery Fuel Gauge Based on Patented Impedance Track™ Technology**
  - Models the Battery Discharge Curve for Accurate Time-to-Empty Predictions
  - Automatically Adjusts for Battery Aging, Battery Self-Discharge, and Temperature/Rate Inefficiencies
  - **Low-Value Sense Resistor (10 mΩ or Less)**
- **I<sup>2</sup>C™ Interface for Connection to System Microcontroller Port**
- **12-Pin 2,5-mm × 4-mm SON Package**

### 1.2 APPLICATIONS

- **Smartphones**
- **PDA's**
- **Digital Still and Video Cameras**
- **Handheld Terminals**
- **MP3 or Multimedia Players**

### 1.3 DESCRIPTION

The Texas Instruments bq27501 system-side Li-Ion battery fuel gauge is a microcontroller peripheral that provides fuel gauging for single-cell Li-Ion battery packs. The device requires little system microcontroller firmware development. The bq27501 resides on the system main board, and manages an embedded battery (non-removable) or a removable battery pack.

The device uses the patented Impedance Track™ algorithm for fuel gauging, and provides information such as remaining battery capacity (mAh), state-of-charge (%), run-time to empty (min.), battery voltage (mV), and temperature (°C).

The device works with identification resistors in battery packs to gauge batteries of different fundamental chemistries and/or different rated capacities.

### TYPICAL APPLICATION

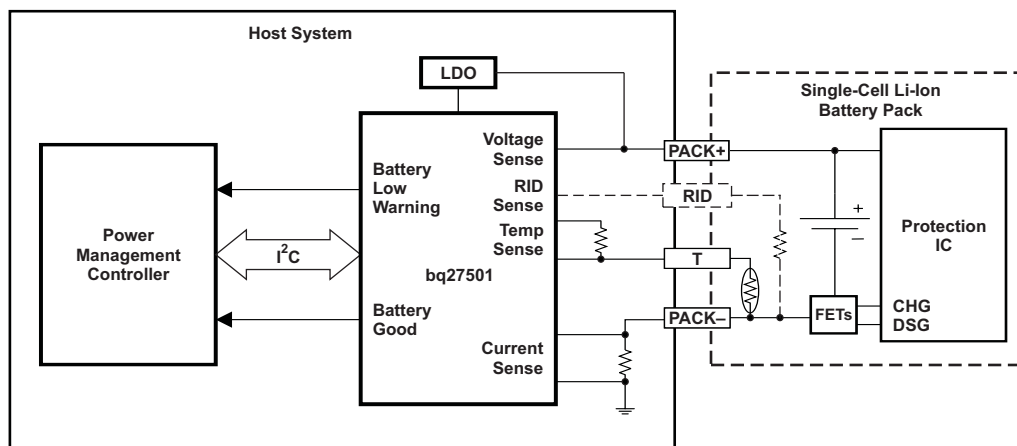

Please be aware that an important notice concerning availability, standard warranty, and use in critical applications of Texas Instruments semiconductor products and disclaimers thereto appears at the end of this document.

Impedance Track, bqEASY are trademarks of Texas Instruments.  
I<sup>2</sup>C is a trademark of Philips Electronics.

# System-Side Impedance Track™ Fuel Gauge

SLUS879A–OCTOBER 2008–REVISED JUNE 2009

www.ti.com

## Contents

<b>1 INTRODUCTION</b> .....	<b>1</b>	4.3 MANUFACTURER INFORMATION BLOCKS .....	<b>17</b>
1.1 FEATURES .....	<b>1</b>	4.4 ACCESS MODES .....	<b>17</b>
1.2 APPLICATIONS .....	<b>1</b>	4.5 SEALING/UNSEALING DATA FLASH .....	<b>17</b>
1.3 DESCRIPTION .....	<b>1</b>	4.6 DATA FLASH SUMMARY .....	<b>18</b>
<b>2 DEVICE INFORMATION</b> .....	<b>3</b>	<b>5 FUNCTIONAL DESCRIPTION</b> .....	<b>20</b>
2.1 AVAILABLE OPTIONS .....	<b>3</b>	5.1 FUEL GAUGING .....	<b>20</b>
2.2 DISSIPATION RATINGS .....	<b>3</b>	5.2 IMPEDANCE TRACK™ VARIABLES .....	<b>20</b>
2.3 PIN DIAGRAMS .....	<b>3</b>	5.3 DETAILED DESCRIPTION OF DEDICATED PINS .....	<b>23</b>
<b>3 ELECTRICAL SPECIFICATIONS</b> .....	<b>4</b>	5.4 TEMPERATURE MEASUREMENT .....	<b>24</b>
3.1 ABSOLUTE MAXIMUM RATINGS .....	<b>4</b>	5.5 OVERTEMPERATURE INDICATION .....	<b>25</b>
3.2 RECOMMENDED OPERATING CONDITIONS .....	<b>4</b>	5.6 CHARGING AND CHARGE-TERMINATION INDICATION .....	<b>25</b>
3.3 POWER-ON RESET .....	<b>5</b>	5.7 POWER MODES .....	<b>25</b>
3.4 INTERNAL TEMPERATURE SENSOR CHARACTERISTICS .....	<b>5</b>	5.8 POWER CONTROL .....	<b>28</b>
3.5 HIGH-FREQUENCY OSCILLATOR .....	<b>5</b>	5.9 AUTOCALIBRATION .....	<b>29</b>
3.6 LOW-FREQUENCY OSCILLATOR .....	<b>5</b>	<b>6 APPLICATION-SPECIFIC INFORMATION</b> .....	<b>29</b>
3.7 INTEGRATING ADC (COULOMB COUNTER) CHARACTERISTICS .....	<b>6</b>	6.1 BATTERY PROFILE STORAGE AND SELECTION .....	<b>29</b>
3.8 ADC (TEMPERATURE AND CELL MEASUREMENT) CHARACTERISTICS .....	<b>6</b>	6.2 APPLICATION-SPECIFIC FLOW AND CONTROL .....	<b>30</b>
3.9 DATA FLASH MEMORY CHARACTERISTICS .....	<b>6</b>	<b>7 COMMUNICATIONS</b> .....	<b>31</b>
3.10 I <sup>2</sup> C-COMPATIBLE INTERFACE COMMUNICATION TIMING CHARACTERISTICS .....	<b>7</b>	7.1 I <sup>2</sup> C INTERFACE .....	<b>31</b>
<b>4 GENERAL DESCRIPTION</b> .....	<b>8</b>	7.2 I <sup>2</sup> C TIME OUT .....	<b>31</b>
4.1 DATA COMMANDS .....	<b>9</b>	7.3 I <sup>2</sup> C Command Waiting Time .....	<b>32</b>
4.2 DATA FLASH INTERFACE .....	<b>16</b>	<b>8 REFERENCE SCHEMATICS</b> .....	<b>33</b>
		8.1 SCHEMATIC .....	<b>33</b>
		<b>8 REFERENCE SCHEMATICS</b> .....	<b>34</b>
		8.1 SCHEMATIC .....	<b>34</b>

## 2 DEVICE INFORMATION

### 2.1 AVAILABLE OPTIONS

PART NUMBER	FIRMWARE VERSION <sup>(1)</sup>	PACKAGE <sup>(2)</sup>	T <sub>A</sub>	COMMUNICATION FORMAT	TAPE and REEL QUANTITY
bq27501DRZR	1.20	12-pin, 2,5-mm × 4-mm SON	–40°C to 85°C	I <sup>2</sup> C	3000
bq27501DRZT					250

- (1) Ordering the device with the latest firmware version is recommended. To check the firmware revision and Errata list see [SLUZ015](#)  
(2) For the most current package and ordering information, see the Package Option Addendum at the end of this document, or see the TI website at [www.ti.com](http://www.ti.com).

### 2.2 DISSIPATION RATINGS

PACKAGE	T <sub>A</sub> ≤ 40°C POWER RATING	DERATING FACTOR T <sub>A</sub> > 40°C	R <sub>θJA</sub>
12-pin DRZ <sup>(1)</sup>	482 mW	5.67 mW/°C	176°C/W

- (1) This data is based on using a four-layer JEDEC high-K board with the exposed die pad connected to a Cu pad on the board. The board pad is connected to the ground plane by a 2- × 2-via matrix.

### 2.3 PIN DIAGRAMS

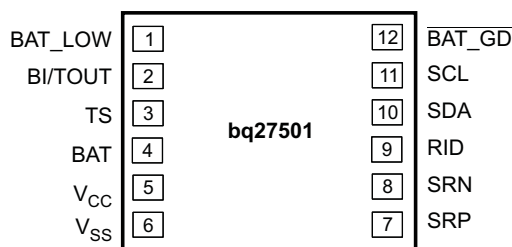

**Table 2-1. PIN FUNCTIONS**

PIN		TYPE <sup>(1)</sup>	DESCRIPTION
NAME	PIN NO.		
BAT	4	I	Cell-voltage measurement input. ADC input. Decouple with 0.1μF capacitor.
$\overline{\text{BAT\_GD}}$	12	O	Battery-good indicator. Active-low by default, though polarity can be configured through the [BATG_POL] of <b>Operation Configuration</b> . Open-drain output
BAT_LOW	1	O	Battery-low output indicator. Active-high by default, though polarity can be configured through the [BATL_POL] in <b>Operation Configuration</b> . Push-pull output
BI/TOUT	2	I/O	Battery-insertion detection input. Power pin for pack thermistor network. Thermistor multiplexer control pin. Push-pull output. Use with pullup resistor > 1 MΩ (1.8 MΩ typical).
RID	9	I	Resistor ID input. Analog input with current sourcing capabilities
SCL	11	I	Slave I <sup>2</sup> C serial communications clock input line for communication with system (master). Open-drain I/O. Use with 10-kΩ pullup resistor (typical).
SDA	10	I/O	Slave I <sup>2</sup> C serial communications data line for communication with system (master). Open-drain I/O. Use with 10-kΩ pullup resistor (typical).
SRN	8	IA	Analog input pin connected to the internal coulomb counter where SRN is nearest the System V <sub>SS</sub> connection. Connect to 5-mΩ to 20-mΩ sense resistor.
SRP	7	IA	Analog input pin connected to the internal coulomb counter, where SRP is nearest the PACK– connection. Connect to 5-mΩ to 20-mΩ sense resistor.
TS	3	IA	Pack thermistor voltage sense (require the use of NTC 103AT-type thermistor). ADC input
V <sub>CC</sub>	5	P	Processor power input. Decouple with 0.1-μF minimum capacitor.
V <sub>SS</sub>	6	P	Device ground. Electrically connected to the IC exposed thermal pad (do not use thermal pad as primary ground. Connect thermal pad to V <sub>SS</sub> via a PCB trace).

- (1) I = Digital input, O = Digital output, I/O = Digital input/output, IA = Analog input, P = Power connection

## System-Side Impedance Track™ Fuel Gauge

SLUS879A–OCTOBER 2008–REVISED JUNE 2009

www.ti.com

### 3 ELECTRICAL SPECIFICATIONS

#### 3.1 ABSOLUTE MAXIMUM RATINGS

over operating free-air temperature range (unless otherwise noted)<sup>(1)</sup>

PARAMETER		VALUE	UNIT
V <sub>CC</sub>	Supply voltage range	−0.3 to 2.75	V
V <sub>IOD</sub>	Open-drain I/O pins (SDA, SDL, $\overline{\text{BAT\_GD}}$ )	−0.3 to 6	V
V <sub>BAT</sub>	BAT input pin	−0.3 to 6	
V <sub>I</sub>	Input voltage range to all other pins (BI/TOUT, TS, SRP, SRN, RID)	−0.3 to V <sub>CC</sub> + 0.3	V
ESD	Human-body model (HBM), BAT pin	1.5	kV
	Human-body model (HBM), all other pins	2	
T <sub>A</sub>	Operating free-air temperature range	−40 to 85	°C
T <sub>F</sub>	Functional temperature range	−40 to 100	°C
T <sub>stg</sub>	Storage temperature range	−65 to 150	°C

(1) Stresses beyond those listed under "absolute maximum ratings" may cause permanent damage to the device. These are stress ratings only, and functional operation of the device at these or any other conditions beyond those indicated under "recommended operating conditions" is not implied. Exposure to absolute-maximum-rated conditions for extended periods may affect device reliability.

#### 3.2 RECOMMENDED OPERATING CONDITIONS

T<sub>A</sub> = −40°C to 85°C; Typical values at T<sub>A</sub> = 25°C and V<sub>CC</sub> = 2.5 V (unless otherwise noted)

PARAMETER		TEST CONDITIONS	MIN	TYP	MAX	UNIT
V <sub>CC</sub>	Supply voltage		2.4	2.5	2.6	V
I <sub>CC</sub>	Normal operating-mode current	Fuel gauge in NORMAL mode. I <sub>LOAD</sub> > <b>Sleep Current</b>		114		μA
I <sub>SLP+</sub>	Sleep+ operating-mode current	Fuel gauge in SLEEP+ mode. I <sub>LOAD</sub> < <b>Sleep Current</b>		58		μA
I <sub>SLP</sub>	Low-power storage-mode current	Fuel gauge in SLEEP mode. I <sub>LOAD</sub> < <b>Sleep Current</b>		19		μA
I <sub>HIB</sub>	Hibernate operating-mode current	Fuel gauge in HIBERNATE mode. I <sub>LOAD</sub> < <b>Hibernate Current</b>		4		μA
V <sub>OL</sub>	Output voltage, low (SDA, BAT_LOW, BI/TOUT)	I <sub>OL</sub> = 3 mA			0.4	V
V <sub>OH(PP)</sub>	Output voltage, high (BAT_LOW, BI/TOUT)	I <sub>OH</sub> = −1 mA	V <sub>CC</sub> − 0.5			V
V <sub>OH(OD)</sub>	Output voltage, high (SDA, SCL, $\overline{\text{BAT\_GD}}$ )	External pullup resistor connected to V <sub>CC</sub>	V <sub>CC</sub> − 0.5			V
V <sub>IL</sub>	Input voltage, low (SDA, SCL)		−0.3		0.6	V
	Input voltage, low (BI/TOUT)	BAT INSERT CHECK MODE active	−0.3		0.6	
V <sub>IH(OD)</sub>	Input voltage, high (SDA, SCL)		1.2		6	
	Input voltage, high (BI/TOUT)	BAT INSERT CHECK MODE active	1.2		V <sub>CC</sub> + 0.3	
C <sub>IN</sub>	Input capacitance (SDA, SCL, BI/TOUT)			35		pF
V <sub>A1</sub>	Input voltage range (TS, RID)		V <sub>SS</sub> − 0.125		2	V
V <sub>A2</sub>	Input voltage range (BAT)		V <sub>SS</sub> − 0.125		5	V
V <sub>A3</sub>	Input voltage range (SRP, SRN)		V <sub>SS</sub> − 0.125		0.125	V
I <sub>lkg</sub>	Input leakage current (I/O pins)				0.3	μA
t <sub>PUCD</sub>	Power-up communication delay			250		ms

### 3.3 POWER-ON RESET

$T_A = -40^{\circ}\text{C}$  to  $85^{\circ}\text{C}$ , typical values at  $T_A = 25^{\circ}\text{C}$  and  $V_{\text{BAT}} = 3.6\text{ V}$  (unless otherwise noted)

PARAMETER	TEST CONDITIONS	MIN	TYP	MAX	UNIT
$V_{\text{IT+}}$	Positive-going battery voltage input at $V_{\text{CC}}$	2.09	2.2	2.31	V
$V_{\text{HYS}}$	Hysteresis voltage	45	115	185	mV

### 3.4 INTERNAL TEMPERATURE SENSOR CHARACTERISTICS

$T_A = -40^{\circ}\text{C}$  to  $85^{\circ}\text{C}$ ,  $2.4\text{ V} < V_{\text{CC}} < 2.6\text{ V}$ ; typical values at  $T_A = 25^{\circ}\text{C}$  and  $V_{\text{CC}} = 2.5\text{ V}$  (unless otherwise noted)

PARAMETER	TEST CONDITIONS	MIN	TYP	MAX	UNIT
$G_{\text{TEMP}}$	Temperature sensor voltage gain		-2		mV/ $^{\circ}\text{C}$

### 3.5 HIGH-FREQUENCY OSCILLATOR

$T_A = -40^{\circ}\text{C}$  to  $85^{\circ}\text{C}$ ,  $2.4\text{ V} < V_{\text{CC}} < 2.6\text{ V}$ ; typical values at  $T_A = 25^{\circ}\text{C}$  and  $V_{\text{CC}} = 2.5\text{ V}$  (unless otherwise noted)

PARAMETER	TEST CONDITIONS	MIN	TYP	MAX	UNIT
$f_{\text{OSC}}$	Operating frequency		2.097		MHz
$f_{\text{EIO}}$	Frequency error <sup>(1)</sup> <sup>(2)</sup>	$T_A = 0^{\circ}\text{C}$ to $60^{\circ}\text{C}$	-2%	0.38%	2%
		$T_A = -20^{\circ}\text{C}$ to $70^{\circ}\text{C}$	-3%	0.38%	3%
		$T_A = -40^{\circ}\text{C}$ to $85^{\circ}\text{C}$	-4.5%	0.38%	4.5%
$t_{\text{SXO}}$	Start-up time <sup>(3)</sup>		2.5	5	ms

(1) The frequency error is measured from 2.097 MHz.

(2) The frequency drift is included and measured from the trimmed frequency at  $V_{\text{CC}} = 2.5\text{ V}$ ,  $T_A = 25^{\circ}\text{C}$ .

(3) The start-up time is defined as the time it takes for the oscillator output frequency to be within  $\pm 3\%$  of typical oscillator frequency.

### 3.6 LOW-FREQUENCY OSCILLATOR

$T_A = -40^{\circ}\text{C}$  to  $85^{\circ}\text{C}$ ,  $2.4\text{ V} < V_{\text{CC}} < 2.6\text{ V}$ ; typical values at  $T_A = 25^{\circ}\text{C}$  and  $V_{\text{CC}} = 2.5\text{ V}$  (unless otherwise noted)

PARAMETER	TEST CONDITIONS	MIN	TYP	MAX	UNIT
$f_{\text{LOSC}}$	Operating frequency		32.768		kHz
$f_{\text{LEIO}}$	Frequency error <sup>(1)</sup> <sup>(2)</sup>	$T_A = 0^{\circ}\text{C}$ to $60^{\circ}\text{C}$	-1.5%	0.25%	1.5%
		$T_A = -20^{\circ}\text{C}$ to $70^{\circ}\text{C}$	-2.5%	0.25%	2.5%
		$T_A = -40^{\circ}\text{C}$ to $85^{\circ}\text{C}$	-4%	0.25%	4%
$t_{\text{LSXO}}$	Start-up time <sup>(3)</sup>			500	$\mu\text{s}$

(1) The frequency drift is included and measured from the trimmed frequency at  $V_{\text{CC}} = 2.5\text{ V}$ ,  $T_A = 25^{\circ}\text{C}$ .

(2) The frequency error is measured from 32.768 kHz.

(3) The start-up time is defined as the time it takes for the oscillator output frequency to be within  $\pm 3\%$  of typical oscillator frequency.

## System-Side Impedance Track™ Fuel Gauge

SLUS879A–OCTOBER 2008–REVISED JUNE 2009

www.ti.com

### 3.7 INTEGRATING ADC (COULOMB COUNTER) CHARACTERISTICS

 $T_A = -40^\circ\text{C}$  to  $85^\circ\text{C}$ ,  $2.4\text{ V} < V_{CC} < 2.6\text{ V}$ ; typical values at  $T_A = 25^\circ\text{C}$  and  $V_{CC} = 2.5\text{ V}$  (unless otherwise noted)

PARAMETER		TEST CONDITIONS	MIN	TYP	MAX	UNIT
$V_{I(SR)}$	Input voltage range ( $V_{SR} = V_{(SRN)} - V_{(SRP)}$ )		-0.125		0.125	V
$t_{SR\_CONV}$	Conversion time	Single conversion		1		s
	Resolution		14		15	bits
$V_{OS(SR)}$	Input offset			10		$\mu\text{V}$
INL	Integral nonlinearity error			$\pm 0.007$	$\pm 0.034$	% FSR
$Z_{IN(SR)}$	Effective input resistance <sup>(1)</sup>		2.5			$\text{M}\Omega$
$I_{lkq(SR)}$	Input leakage current <sup>(1)</sup>				0.3	$\mu\text{A}$

(1) Specified by design. Not tested in production.

### 3.8 ADC (TEMPERATURE AND CELL MEASUREMENT) CHARACTERISTICS

 $T_A = -40^\circ\text{C}$  to  $85^\circ\text{C}$ ,  $2.4\text{ V} < V_{CC} < 2.6\text{ V}$ ; typical values at  $T_A = 25^\circ\text{C}$  and  $V_{CC} = 2.5\text{ V}$  (unless otherwise noted)

PARAMETER		TEST CONDITIONS	MIN	TYP	MAX	UNIT
$V_{IN(ADC)}$	Input voltage range		-0.2		1	V
$t_{ADC\_CONV}$	Conversion time				125	ms
	Resolution		14		15	bits
$V_{OS(ADC)}$	Input offset			1		mV
$Z_{IN(ADC1)}$	Effective input resistance (TS, RID) <sup>(1)</sup>		8			$\text{M}\Omega$
$Z_{IN(ADC2)}$	Effective input resistance (BAT) <sup>(1)</sup>	bq27501 not measuring cell voltage	8			$\text{M}\Omega$
		bq27501 measuring cell voltage		100		$\text{k}\Omega$
$I_{lkq(ADC)}$	Input leakage current <sup>(1)</sup>				0.3	$\mu\text{A}$

(1) Specified by design. Not tested in production.

### 3.9 DATA FLASH MEMORY CHARACTERISTICS

 $T_A = -40^\circ\text{C}$  to  $85^\circ\text{C}$ ,  $2.4\text{ V} < V_{CC} < 2.6\text{ V}$ ; typical values at  $T_A = 25^\circ\text{C}$  and  $V_{CC} = 2.5\text{ V}$  (unless otherwise noted)

PARAMETER		TEST CONDITIONS	MIN	TYP	MAX	UNIT
$t_{ON}$	Data retention <sup>(1)</sup>		10			Years
	Flash-programming write cycles <sup>(1)</sup>		20,000			Cycles
$t_{WORDPROG}$	Word programming time <sup>(1)</sup>				2	ms
$I_{CCPROG}$	Flash-write supply current <sup>(1)</sup>			5	10	mA

(1) Specified by design. Not production tested

### 3.10 I<sup>2</sup>C-COMPATIBLE INTERFACE COMMUNICATION TIMING CHARACTERISTICS

$T_A = -40^{\circ}\text{C}$  to  $85^{\circ}\text{C}$ ,  $2.4\text{ V} < V_{CC} < 2.6\text{ V}$ ; typical values at  $T_A = 25^{\circ}\text{C}$  and  $V_{CC} = 2.5\text{ V}$  (unless otherwise noted)

PARAMETER	TEST CONDITIONS	MIN	TYP	MAX	UNIT
$t_r$	SCL/SDA rise time			300	ns
$t_f$	SCL/SDA fall time			300	ns
$t_{w(H)}$	SCL pulse duration (high)	600			ns
$t_{w(L)}$	SCL pulse duration (low)	1.3			$\mu\text{s}$
$t_{su(STA)}$	Setup for repeated start	600			ns
$t_{d(STA)}$	Start to first falling edge of SCL	600			ns
$t_{su(DAT)}$	Data setup time	1000			ns
$t_{h(DAT)}$	Data hold time	0			ns
$t_{su(STOP)}$	Setup time for stop	600			ns
$t_{(BUF)}$	Bus free time between stop and start	66			$\mu\text{s}$
$f_{SCL}$	Clock frequency			400	kHz

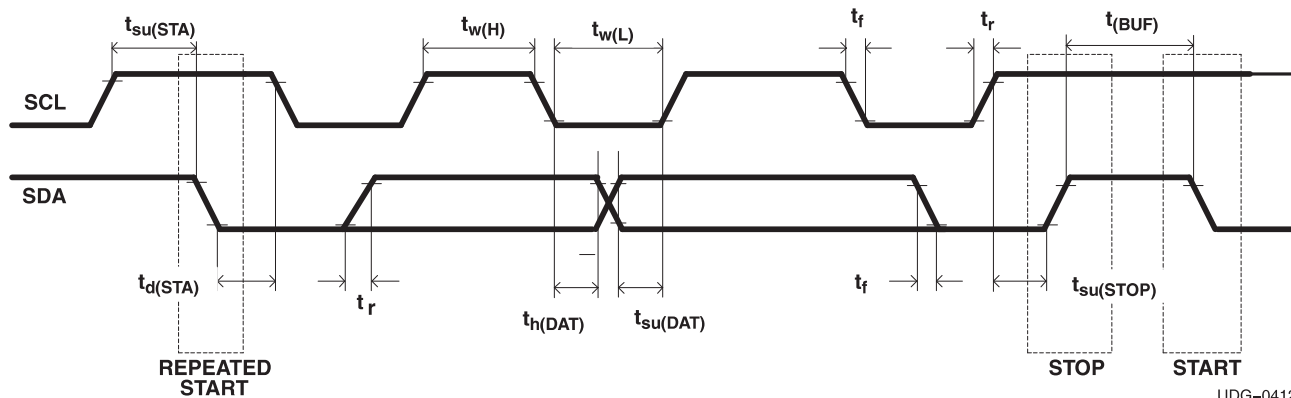

Figure 3-1. I<sup>2</sup>C-Compatible Interface Timing Diagrams

## System-Side Impedance Track™ Fuel Gauge

SLUS879A–OCTOBER 2008–REVISED JUNE 2009

www.ti.com

### 4 GENERAL DESCRIPTION

The bq27501 accurately predicts the battery capacity and other operational characteristics of a single Li-based rechargeable cell. It can be interrogated by a system processor to provide cell information, such as state-of-charge (SOC), time-to-empty (TTE) and time-to-full (TTF).

Information is accessed through a series of commands, called *Standard Commands*. Further capabilities are provided by the additional *Extended Commands* set. Both sets of commands, indicated by the general format *Command( )*, are used to read and write information contained within the bq27501 control and status registers, as well as its data flash locations. Commands are sent from system to gauge using the bq27501 I<sup>2</sup>C serial communications engine, and can be executed during application development, pack manufacture, or end-equipment operation.

Cell information is stored in the bq27501 in non-volatile flash memory. Many of these data flash locations are accessible during application development. They cannot be accessed directly during end-equipment operation. Access to these locations is achieved by either use of the bq27501 companion evaluation software, through individual commands, or through a sequence of data-flash-access commands. To access a desired data flash location, the correct data flash subclass and offset must be known.

The bq27501 provides 96 bytes of user-programmable data flash memory, partitioned into three 32-byte blocks: **Manufacturer Info Block A**, **Manufacturer Info Block B**, and **Manufacturer Info Block C**. This data space is accessed through a data flash interface. For specifics on accessing the data flash, see [Section 4.3, Manufacturer Information Blocks](#).

The key to the high-accuracy fuel gauging prediction of the bq27501 is Texas Instruments' proprietary Impedance Track™ algorithm. This algorithm uses cell measurements, characteristics, and properties to create state-of-charge predictions that can achieve less than 1% error across a wide variety of operating conditions and over the lifetime of the battery.

The bq27501 measures charge/discharge activity by monitoring the voltage across a small-value series sense resistor (5 mΩ to 20 mΩ, typ.) located between the system V<sub>ss</sub> and the battery PACK– terminal. When a cell is attached to the bq27501, cell impedance is computed, based on cell current, cell open-circuit voltage (OCV), and cell voltage under loading conditions.

The bq27501 external temperature sensing is optimized with the use of a high accuracy negative temperature coefficient (NTC) thermistor with  $R_{25} = 10.0K\Omega \pm 1\%$  and  $B_{25/85} = 3435K \pm 1\%$  (such as Semitec 103AT for measurement). The bq27501 can also be configured to use its internal temperature sensor. When an external thermistor is used, a 18.2k pull up resistor between BT/TOUT and TS pins is also required. The bq27501 uses temperature to monitor the battery-pack environment, which is used for fuel gauging and cell protection functionality.

To minimize power consumption, the bq27501 has deferential power modes: BAT INSERT CHECK, NORMAL, SLEEP+, SLEEP and HIBERNATE. The bq27501 passes automatically between these modes, depending upon the occurrence of specific events, though a system processor can initiate some of these modes directly. More details can be found in [Section 5.7, Power Modes](#).

---

#### NOTE

##### FORMATTING CONVENTIONS IN THIS DOCUMENT:

Commands: *italics* with parentheses and no breaking spaces, e.g., *RemainingCapacity( )*.

Data flash: *italics*, **bold**, and *breaking spaces*, e.g., **Design Capacity**

Register bits and flags: brackets and *italics*, e.g., [TDA]

Data flash bits: brackets, *italics* and **bold**, e.g., [LED1]

Modes and states: ALL CAPITALS, e.g., UNSEALED mode.

---

## 4.1 DATA COMMANDS

### 4.1.1 STANDARD DATA COMMANDS

The bq27501 uses a series of 2-byte standard commands to enable system reading and writing of battery information. Each standard command has an associated command-code pair, as indicated in [Table 4-1](#). Because each command consists of two bytes of data, two consecutive I<sup>2</sup>C transmissions must be executed both to initiate the command function, and to read or write the corresponding two bytes of data. Additional options for transferring data, such as spooling, are described in [Section 7, I<sup>2</sup>C Interface](#). Standard commands are accessible in NORMAL operation.

**Table 4-1. Standard Commands**

NAME		COMMAND CODE	UNITS	SEALED ACCESS
<i>Control()</i>	CNTL	0x00 / 0x01	N/A	R/W
<i>AtRate()</i>	AR	0x02 / 0x03	mA	R/W
<i>AtRateTimeToEmpty()</i>	ARTTE	0x04 / 0x05	Minutes	R
<i>Temperature()</i>	TEMP	0x06 / 0x07	0.1 K	R
<i>Voltage()</i>	VOLT	0x08 / 0x09	mV	R
<i>Flags()</i>	FLAGS	0x0a / 0x0b	N/A	R
<i>NominalAvailableCapacity()</i>	NAC	0x0c / 0x0d	mAh	R
<i>FullAvailableCapacity()</i>	FAC	0x0e / 0x0f	mAh	R
<i>RemainingCapacity()</i>	RM	0x10 / 0x11	mAh	R
<i>FullChargeCapacity()</i>	FCC	0x12 / 0x13	mAh	R
<i>AverageCurrent()</i>	AI	0x14 / 0x15	mA	R
<i>TimeToEmpty()</i>	TTE	0x16 / 0x17	Minutes	R
<i>TimeToFull()</i>	TTF	0x18 / 0x19	Minutes	R
<i>StandbyCurrent()</i>	SI	0x1a / 0x1b	mA	R
<i>StandbyTimeToEmpty()</i>	STTE	0x1c / 0x1d	Minutes	R
<i>MaxLoadCurrent()</i>	MLI	0x1e / 0x1f	mA	R
<i>MaxLoadTimeToEmpty()</i>	MLTTE	0x20 / 0x21	Minutes	R
<i>AvailableEnergy()</i>	AE	0x22 / 0x23	mWh	R
<i>AveragePower()</i>	AP	0x24 / 0x25	mW	R
<i>TimeToEmptyAtConstantPower()</i>	TTECP	0x26 / 0x27	Minutes	R
Reserved	RSVD	0x28 / 0x29	N/A	R
<i>CycleCount()</i>	CC	0x2a / 0x2b	Counts	R
<i>StateOfCharge()</i>	SOC	0x2c / 0x2d	%	R

# System-Side Impedance Track™ Fuel Gauge

SLUS879A–OCTOBER 2008–REVISED JUNE 2009

www.ti.com

## 4.1.1.1 Control(): 0x00/0x01

Issuing a *Control()* command requires a subsequent 2-byte subcommand. These additional bytes specify the particular control function desired. The *Control()* command allows the system to control specific features of the bq27501 during normal operation and additional features when the bq27501 is in different access modes, as described in [Table 4-2](#).

**Table 4-2. Control() Subcommands**

CNTL FUNCTION	CNTL DATA	SEALED ACCESS	DESCRIPTION
CONTROL_STATUS	0x0000	Yes	Reports the status of DF checksum, hibernate, IT, etc.
DEVICE_TYPE	0x0001	Yes	Reports the device type (eg: "bq27501")
FW_VERSION	0x0002	Yes	Reports the firmware version on the device type
HW_VERSION	0x0003	Yes	Reports the hardware version of the device type
DF_CHECKSUM	0x0004	No	Enables a data flash checksum to be generated and reports on a read
RESET_DATA	0x0005	Yes	Returns reset data
Reserved	0x0006	No	Not to be used
PREV_MACWRITE	0x0007	Yes	Returns previous MAC command code
CHEM_ID	0x0008	Yes	Reports the chemical identifier of the Impedance Track™ configuration
BOARD_OFFSET	0x0009	No	Forces the device to measure and store the board offset
CC_INT_OFFSET	0x000a	No	Forces the device to measure the internal CC offset
WRITE_CC_OFFSET	0x000b	No	Forces the device to store the internal CC offset
SET_HIBERNATE	0x0011	Yes	Forces CONTROL_STATUS [HIBERNATE] to 1
CLEAR_HIBERNATE	0x0012	Yes	Forces CONTROL_STATUS [HIBERNATE] to 0
SET_SLEEP+	0x0013	Yes	Forces CONTROL_STATUS [SNOOZE] to 1
CLEAR_SLEEP+	0x0014	Yes	Forces CONTROL_STATUS [SNOOZE] to 0
SEALED	0x0020	No	Places the bq27501 in SEALED access mode
IT_ENABLE	0x0021	No	Enables the Impedance Track™ algorithm
CAL_MODE	0x0040	No	Places the bq27501 in calibration mode
RESET	0x0041	No	Forces a full reset of the bq27501

### 4.1.1.1.1 CONTROL\_STATUS: 0x0000

Instructs the fuel gauge to return status information to control addresses 0x00/0x01. The status word includes the following information.

**Table 4-3. CONTROL\_STATUS Bit Definitions**

Flags()	bit7	bit6	bit5	bit4	bit3	bit2	bit1	bit0
High byte	–	FAS	SS	CSV	CCA	BCA	–	–
Low byte	–	HIBERNATE	SNOOZE	SLEEP	LDMD	RUP_DIS	VOK	QEN

FAS = Status bit indicating the bq27501 is in FULL ACCESS SEALED state. Active when set.

SS = Status bit indicating the bq27501 is in SEALED state. Active when set.

CSV = Status bit indicating a valid data flash checksum has been generated. Active when set.

CCA = Status bit indicating the bq27501 coulomb counter calibration routine is active. Active when set. The first CCA routine will take place approximately 3 minutes and 45 seconds after the initialization

BCA = Status bit indicating the bq27501 board calibration routine is active. Active when set.

HIBERNATE = Status bit indicating a request for entry into HIBERNATE from SLEEP mode. True when set. Default is 0.

SNOOZE = Status bit indicating the bq27501 SLEEP+ mode is enabled. True when set

SLEEP = Status bit indicating the bq27501 is in SLEEP mode. True when set.

LDMD = Status bit indicating the bq27501 Impedance Track™ algorithm is using constant-power mode. True when set. Default is 0 (constant-current mode).

RUP\_DIS = Status bit indicating the bq27501 Ra table updates are disabled. Updates disabled when set.

VOK = Status bit indicating the bq27501 voltages are okay for Qmax. True when set.

QEN = Status bit indicating the bq27501 Qmax updates enabled. True when set.

**4.1.1.1.2 DEVICE\_TYPE: 0x0001**

Instructs the fuel gauge to return the device type to addresses 0x00/0x01.

**4.1.1.1.3 FW\_VERSION: 0x0002**

Instructs the fuel gauge to return the firmware version to addresses 0x00/0x01.

**4.1.1.1.4 HW\_VERSION: 0x0003**

Instructs the fuel gauge to return the hardware version to addresses 0x00/0x01.

**4.1.1.1.5 DF\_CHECKSUM: 0x0004**

Instructs the fuel gauge to compute the checksum of the data flash memory. Once the checksum has been calculated and stored, CONTROL\_STATUS [CVS] is set. The checksum value is written and returned to addresses 0x00/0x01 (UNSEALED mode only). The checksum is not calculated in SEALED mode; however, the checksum value can still be read.

**4.1.1.1.6 RESET\_DATA: 0x0005**

Instructs the fuel gauge to return the reset data to addresses 0x00/0x01.

**4.1.1.1.7 PREV\_MACWRITE: 0x0007**

Instructs the fuel gauge to return the previous command written to addresses 0x00/0x01.

**4.1.1.1.8 CHEM\_ID: 0x0008**

Instructs the fuel gauge to return the chemical identifier for the Impedance Track™ configuration to addresses 0x00/0x01.

**4.1.1.1.9 BOARD\_OFFSET: 0X0009**

Instructs the fuel gauge to compute the coulomb counter offset with internal short and then without internal short applied across the sensing resistor (SR) inputs. The difference between the two measurements is the board offset. After a delay of approximately 32 seconds, this offset value is returned to addresses 0x00/0x01 and written to data flash. The CONTROL STATUS [BCA] is also set. The user must prevent any charge or discharge current from flowing during the process. This function is only available when the fuel gauge is UNSEALED. When SEALED, this command only reads back the board-offset value stored in data flash.

**4.1.1.1.10 CC\_INT\_OFFSET: 0X000A**

Control data of 0x000a instructs the fuel gauge to compute the coulomb counter offset with internal short applied across the SR inputs. The offset value is returned to addresses 0x00/0x01, after a delay of approximately 16 seconds. This function is only available when the fuel gauge is UNSEALED. When SEALED, this command only reads back the CC\_INT\_OFFSET value stored in data flash.

**4.1.1.1.11 WRITE\_OFFSET: 0X000B**

Control data of 0x000b causes the fuel gauge to write the coulomb counter offset to data flash.

**4.1.1.1.12 SET\_HIBERNATE: 0x0011**

Instructs the fuel gauge to force the CONTROL\_STATUS [HIBERNATE] bit to 1. This allows the gauge to enter the HIBERNATE power mode after the transition to SLEEP power state is detected. The [HIBERNATE] bit is automatically cleared upon exiting from HIBERNATE mode.

**4.1.1.1.13 CLEAR\_HIBERNATE: 0x0012**

Instructs the fuel gauge to force the CONTROL\_STATUS [HIBERNATE] bit to 0. This prevents the gauge from entering the HIBERNATE power mode after the transition to the SLEEP power state is detected. It can also be used to force the gauge out of HIBERNATE mode.

## System-Side Impedance Track™ Fuel Gauge

SLUS879A–OCTOBER 2008–REVISED JUNE 2009

www.ti.com

### 4.1.1.1.14 **ENABLE SLEEP+ MODE: 0X0013**

Instructs the fuel gauge to set the CONTROL\_STATUS [SNOOZE] bit to 1. This will enable the SLEEP+ mode. The gauge will enter SLEEP+ power mode after the transition conditions are met.

### 4.1.1.1.15 **DISABLE SLEEP+ MODE: 0X0014**

Instructs the fuel gauge to set the CONTROL\_STATUS [SNOOZE] bit to 0. This will disable the SLEEP+ mode. The gauge will exit from the SLEEP+ power mode after the SNOOZ bit is cleared.

### 4.1.1.1.16 **SEALED: 0x0020**

Instructs the fuel gauge to transition from the UNSEALED state to the SEALED state. The fuel gauge must always be set to the SEALED state for use in end equipment.

### 4.1.1.1.17 **IT\_ENABLE: 0x0021**

This command forces the fuel gauge to begin the Impedance Track™ algorithm, sets the active **UpdateStatus** *n* location to 0x01 and causes the [VOK] and [QEN] flags to be set in the CONTROL\_STATUS register. [VOK] is cleared if the voltages are not suitable for a Qmax update. Once set, [QEN] cannot be cleared. This command is only available when the fuel gauge is UNSEALED.

### 4.1.1.1.18 **CAL\_MODE: 0X0040**

This command instructs the fuel gauge to enter calibration mode. This command is only available when the fuel gauge is UNSEALED.

### 4.1.1.1.19 **RESET: 0x0041**

This command instructs the fuel gauge to perform a full reset. This command is only available when the fuel gauge is UNSEALED.

## 4.1.1.2 **AtRate( ): 0x02/0x03**

The *AtRate( )* read/write function is the first half of a two-function command set used to set the *AtRate* value used in calculations made by the *AtRateTimeToEmpty( )* function. The *AtRate( )* units are in mA.

The *AtRate( )* value is a signed integer, with negative values interpreted as a discharge current value. The *AtRateTimeToEmpty( )* function returns the predicted operating time at the *AtRate* value of discharge. The default value for *AtRate( )* is zero and forces *AtRateTimeToEmpty( )* to return 65,535. Both the *AtRate( )* and *AtRateTimeToEmpty( )* commands must only be used in NORMAL mode.

## 4.1.1.3 **AtRateTimeToEmpty( ): 0x04/0x05**

This read-only function returns an unsigned integer value of the predicted remaining operating time if the battery is discharged at the *AtRate( )* value in minutes with a range of 0 to 65,534. A value of 65,535 indicates *AtRate( )* = 0. The fuel gauge updates *AtRateTimeToEmpty( )* within 1 s after the system sets the *AtRate( )* value. The fuel gauge automatically updates *AtRateTimeToEmpty( )* based on the *AtRate( )* value every 1 s. Both the *AtRate( )* and *AtRateTimeToEmpty( )* commands must only be used in NORMAL mode.

## 4.1.1.4 **Temperature( ): 0x06/0x07**

This read-only function returns an unsigned integer value of the temperature in units of 0.1 K measured by the fuel gauge.

## 4.1.1.5 **Voltage( ): 0x08/0x09**

This read-only function returns an unsigned integer value of the measured cell-pack voltage in mV with a range of 0 to 6,000 mV.

## 4.1.1.6 **Flags( ): 0x0a/0x0b**

This read-only function returns the contents of the fuel-gauge status register, depicting the current operating status.

Table 4-4. Flags Bit Definitions

	bit7	bit6	bit5	bit4	bit3	bit2	bit1	bit0
High byte	OTC	OTD	–	–	CHG_INH	XCHG	FC	CHG
Low byte	–	–	OCV_GD	WAIT_ID	BAT_DET	SOC1	SOCF	DSG

OTC = Overtemperature in charge condition is detected. True when set.

OTD = Overtemperature in discharge condition is detected. True when set.

CHG\_INH = Charge inhibit: unable to begin charging (temperature outside the range [*Charge Inhibit Temp Low, Charge Inhibit Temp High*]). True when set.

XCHG = Charge suspend alert (temperature outside the range [*Suspend Temp Low, Suspend Temp High*]). True when set.

FC = Fully charged. Set when charge termination condition is met (RMFCC = 1; Set FC\_Set% = -1% when RMFCC = 0) . True when set.

CHG = (Fast) charging allowed. True when set.

OCV\_GD = Good OCV measurement taken. True when set.

WAIT\_ID = Waiting to identify inserted battery. True when set.

BAT\_DET = Battery detected. True when set.

SOC1 = State-of-charge threshold 1 (*SOC1 Set Threshold*) reached. True when set.

SOCF = State-of-charge threshold final (*SOCF Set Threshold*) reached. True when set.

DSG = Discharging detected. True when set.

#### 4.1.1.7 *NominalAvailableCapacity()*: 0x0c/0x0d

This read-only command pair returns the uncompensated (less than C/20 load) battery capacity remaining. Units are mAh.

#### 4.1.1.8 *FullAvailableCapacity()*: 0x0e/0x0f

This read-only command pair returns the uncompensated (less than C/20 load) capacity of the battery when fully charged. Units are mAh. *FullAvailableCapacity()* is updated at regular intervals, as specified by the IT algorithm.

#### 4.1.1.9 *RemainingCapacity()*: 0x10/0x11

This read-only command pair returns the compensated battery capacity remaining. Units are mAh.

#### 4.1.1.10 *FullChargeCapacity()*: 0x12/13

This read-only command pair returns the compensated capacity of the battery when fully charged. Units are mAh. *FullChargeCapacity()* is updated at regular intervals, as specified by the IT algorithm.

#### 4.1.1.11 *AverageCurrent()*: 0x14/0x15

This read-only command pair returns a signed integer value that is the average current flow through the sense resistor. It is updated every 1 second. Units are mA.

#### 4.1.1.12 *TimeToEmpty()*: 0x16/0x17

This read-only function returns an unsigned integer value of the predicted remaining battery life at the present rate of discharge, in minutes. A value of 65,535 indicates battery is not being discharged.

#### 4.1.1.13 *TimeToFull()*: 0x18/0x19

This read-only function returns an unsigned integer value of predicted remaining time until the battery reaches full charge, in minutes, based upon *AverageCurrent()*. The computation accounts for the taper current time extension from the linear TTF computation based on a fixed *AverageCurrent()* rate of charge accumulation. A value of 65,535 indicates the battery is not being charged.

#### 4.1.1.14 *StandbyCurrent()*: 0x1a/0x1b

This read-only function returns a signed integer value of the measured standby current through the sense resistor. The *StandbyCurrent()* is an adaptive measurement. Initially it reports the standby current programmed in *Initial Standby*, and after spending several seconds in standby, reports the measured standby current.

## System-Side Impedance Track™ Fuel Gauge

SLUS879A–OCTOBER 2008–REVISED JUNE 2009

www.ti.com

The register value is updated every 1 second when the measured current is above the **Deadband** in [Table 4-7](#) and is less than or equal to  $2 \times$  **Initial Standby**. The first and last values that meet this criteria are not averaged in, because they may not be stable values. To approximate a 1-minute time constant, each new *StandbyCurrent()* value is computed by taking approximate 93% weight of the last standby current and approximate 7% of the current measured average current.

### 4.1.1.15 *StandbyTimeToEmpty()*: 0x1c/0x1d

This read-only function returns an unsigned integer value of the predicted remaining battery life at the standby rate of discharge, in minutes. The computation uses *Nominal Available Capacity* (NAC), the uncompensated remaining capacity, for this computation. A value of 65,535 indicates battery is not being discharged.

### 4.1.1.16 *MaxLoadCurrent()*: 0x1e/0x1f

This read-only function returns a signed integer value, in units of mA, of the maximum load conditions. The *MaxLoadCurrent()* is an adaptive measurement which is initially reported as the maximum load current programmed in **Initial Max Load Current**. If the measured current is ever greater than **Initial Max Load Current**, then *MaxLoadCurrent()* updates to the new current. *MaxLoadCurrent()* is reduced to the average of the previous value and **Initial Max Load Current** whenever the battery is charged to full after a previous discharge to an SOC less than 50%. This prevents the reported value from maintaining an unusually high value.

### 4.1.1.17 *MaxLoadTimeToEmpty()*: 0x20/0x21

This read-only function returns an unsigned integer value of the predicted remaining battery life at the maximum load current discharge rate, in minutes. A value of 65,535 indicates that the battery is not being discharged.

### 4.1.1.18 *AvailableEnergy()*: 0x22/0x23

This read-only function returns an unsigned integer value of the predicted charge or energy remaining in the battery. The value is reported in units of mWh.

### 4.1.1.19 *AveragePower()*: 0x24/0x25

This read-only function returns a signed integer value of the average power during battery charging and discharging. It is negative during discharge and positive during charge. A value of 0 indicates that the battery is not being discharged. The value is reported in units of mW.

### 4.1.1.20 *TimeToEmptyAtConstantPower()*: 0x26/0x27

This read-only function returns an unsigned integer value of the predicted remaining operating time if the battery is discharged at the *AveragePower()* value in minutes. A value of 65,535 indicates *AveragePower()* = 0. The fuel gauge automatically updates *TimeToEmptyatContantPower()* based on the *AveragePower()* value every 1 s.

### 4.1.1.21 *CycleCount()*: 0x2a/0x2b

This read-only function returns an unsigned integer value of the number of cycles the battery has experienced with a range of 0 to 65,535. One cycle occurs when accumulated discharge  $\geq$  **CC Threshold**.

### 4.1.1.22 *StateOfCharge()*: 0x2c/0x2d

This read-only function returns an unsigned integer value of the predicted remaining battery capacity expressed as a percentage of *FullChargeCapacity()*, with a range of 0 to 100%.

## 4.1.2 EXTENDED DATA COMMANDS

Extended commands offer additional functionality beyond the standard set of commands. They are used in the same manner; however, unlike standard commands, extended commands are not limited to 2-byte words. The number of commands bytes for a given extended command ranges in size from single to multiple bytes, as specified in [Table 4-5](#).

Table 4-5. Extended Data Commands

NAME	COMMAND CODE	UNITS	SEALED ACCESS <sup>(1) (2)</sup>	UNSEALED ACCESS <sup>(1) (2)</sup>
Reserved	RSVD	0x34...0x3b	N/A	R
<i>DesignCapacity()</i>	DCAP	0x3c / 0x3d	mAh	R
<i>DataFlashClass()</i> <sup>(2)</sup>	DFCLS	0x3e	N/A	R/W
<i>DataFlashBlock()</i> <sup>(2)</sup>	DFBLK	0x3f	N/A	R/W
<i>BlockData()</i>	DFD	0x40...0x5f	N/A	R
<i>BlockDataChecksum()</i>	DFDCKS	0x60	N/A	R/W
<i>BlockDataControl()</i>	DFDCNTL	0x61	N/A	R/W
<i>DeviceNameLength()</i>	DNAMELEN	0x62	N/A	R
<i>DeviceName()</i>	DNAME	0x63...0x69	N/A	R
<i>ApplicationStatus()</i>	APPSTAT	0x6a	N/A	R
Reserved	RSVD	0x6b...0x7f	N/A	R

(1) SEALED and UNSEALED states are entered via commands to CNTL 0x00/0x01.

(2) In sealed mode, data flash CANNOT be accessed through commands 0x3e and 0x3f.

#### 4.1.2.1 *DesignCapacity()*: 0x3c/0x3d

SEALED and UNSEALED Access: This command returns the theoretical or nominal capacity of a new pack. The value is stored in **Design Capacity** and is expressed in mAh. This is intended to be the theoretical or nominal capacity of a new pack, but has no bearing on the operation of the fuel gauge functionality.

#### 4.1.2.2 *DataFlashClass()*: 0x3e

UNSEALED Access: This command sets the data flash class to be accessed. The class to be accessed must be entered in hexadecimal.

SEALED Access: This command is not available in SEALED mode.

#### 4.1.2.3 *DataFlashBlock()*: 0x3f

UNSEALED Access: This command sets the data flash block to be accessed. When 0x00 is written to *BlockDataControl()*, *DataFlashBlock()* holds the block number of the data flash to be read or written. Example: writing a 0x00 to *DataFlashBlock()* specifies access to the first 32-byte block, a 0x01 specifies access to the second 32-byte block, and so on.

SEALED Access: This command directs which data flash block is accessed by the *BlockData()* command. Writing a 0x00 to *DataFlashBlock()* specifies that the *BlockData()* command transfers authentication data. Issuing a 0x01, 0x02, or 0x03 instructs the *BlockData()* command to transfer **Manufacturer Info Block A**, **B**, or **C**, respectively.

#### 4.1.2.4 *BlockData()*: 0x40...0x5f

This command range is the 32-byte data block used to access **Manufacturer Info Block A**, **B**, or **C**.

UNSEALED access is read/write. SEALED access is read only.

#### 4.1.2.5 *BlockDataChecksum()*: 0x60

UNSEALED Access: This byte contains the checksum on the 32 bytes of block data read or written to data flash. The least-significant byte of the sum of the data bytes written must be complemented ( $[255 - x]$ , for  $x$  the least-significant byte) before being written to 0x60.

SEALED Access: This byte contains the checksum for the 32 bytes of block data written to **Manufacturer Info Block A**, **B**, or **C**. The least-significant byte of the sum of the data bytes written must be complemented ( $[255 - x]$ , for  $x$  the least-significant byte) before being written to 0x60.

## System-Side Impedance Track™ Fuel Gauge

SLUS879A–OCTOBER 2008–REVISED JUNE 2009

www.ti.com

### 4.1.2.6 *BlockDataControl()*: 0x61

UNSEALED Access: This command is used to control data flash access mode. Writing 0x00 to this command enables *BlockData()* to access general data flash. Writing a 0x01 to this command enables SEALED mode operation of *DataFlashBlock()*.

SEALED Access: This command is not available in SEALED mode.

### 4.1.2.7 *DeviceNameLength()*: 0x62

UNSEALED and SEALED Access: This byte contains the length of the **Device Name**.

### 4.1.2.8 *DeviceName()*: 0x63...0x69

UNSEALED and SEALED Access: This block contains the device name that is programmed in **Device Name**.

### 4.1.2.9 *ApplicationStatus()*: 0x6a

This byte function allows the system to read the bq27501 **Application Status** data flash location. See [Table 6-1](#) for specific bit definitions.

### 4.1.2.10 Reserved — 0x6b–0x7f

## 4.2 DATA FLASH INTERFACE

### 4.2.1 ACCESSING THE DATA FLASH

The bq27501 data flash is a non-volatile memory that contains bq27501 initialization, default, cell status, calibration, configuration, and user information. The data flash can be accessed in several different ways, depending on what mode the bq27501 is operating in and what data is being accessed.

Commonly accessed data flash memory locations, frequently read by a system, are conveniently accessed through specific instructions, already described in [Section 4.1, DATA COMMANDS](#). These commands are available when the bq27501 is either in UNSEALED or SEALED modes.

Most data flash locations, however, are only accessible in UNSEALED mode by use of the bq27501 evaluation software or by data flash block transfers. These locations must be optimized and/or fixed during the development and manufacture processes. They become part of a golden image file and can then be written to multiple battery packs. Once established, the values generally remain unchanged during end-equipment operation.

To access data flash locations individually, the block containing the desired data flash location(s) must be transferred to the command register locations, where the information can be read to the system or changed directly. This is accomplished by sending the setup command *BlockDataControl()* (0x61) with data 0x00. Up to 32 bytes of data can be read directly from the *BlockData()* (0x40...0x5f), externally altered, then rewritten to the *BlockData()* command space. Alternatively, specific locations can be read, altered, and rewritten if their corresponding offsets are used to index into the *BlockData()* command space. Finally, the data residing in the command space is transferred to data flash, once the correct checksum for the whole block is written to *BlockDataChecksum()* (0x60).

Occasionally, a data flash CLASS is larger than the 32-byte block size. In this case, the *DataFlashBlock()* command is used to designate in which 32-byte block the desired information resides. The correct command address is then given by  $0x40 + \text{offset modulo } 32$ . For example, to access **Terminate Voltage** in the *Fuel Gauging* class, *DataFlashClass()* is issued 80 (0x50) to set the class. Because the offset is 48, it must reside in the second 32-byte block. Hence, *DataFlashBlock()* is issued 0x01 to set the block offset, and the offset used to index into the *BlockData()* memory area is  $0x40 + 48 \text{ modulo } 32 = 0x40 + 16 = 0x40 + 0x10 = 0x50$ .

Reading and writing subclass data are block operations up to 32 bytes in length. If during a write the data length exceeds the maximum block size, then the data is ignored.

None of the data written to memory are bounded by the bq27501– the values are not rejected by the fuel gauge. Writing an incorrect value may result in hardware failure due to firmware program interpretation of the invalid data. The written data is persistent, so a power-on reset does resolve the fault.

### 4.3 MANUFACTURER INFORMATION BLOCKS

The bq27501 contains 96 bytes of user programmable data flash storage: **Manufacturer Info Block A**, **Manufacturer Info Block B**, **Manufacturer Info Block C**. The method for accessing these memory locations is slightly different, depending on whether the device is in UNSEALED or SEALED modes.

When in UNSEALED mode and when 0x00 has been written to *BlockDataControl()*, accessing the manufacturer information blocks is identical to accessing general data flash locations. First, a *DataFlashClass()* command is used to set the subclass, then a *DataFlashBlock()* command sets the offset for the first data flash address within the subclass. The *BlockData()* command codes contain the referenced data flash data. When writing the data flash, a checksum is expected to be received by *BlockDataChecksum()*. Only when the checksum is received and verified is the data actually written to data flash.

As an example, the data flash location for **Manufacturer Info Block B** is defined as having a Subclass = 58 and an Offset = 32 through 63 (32 byte block). The specification of Class = System Data is not needed to address **Manufacturer Info Block B**, but is used instead for grouping purposes when viewing data flash info in the bq27501 evaluation software.

When in SEALED mode or when 0x01 *BlockDataControl()* does not contain 0x00, data flash is no longer available in the manner used in UNSEALED mode. Rather than issuing subclass information, a designated manufacturer information block is selected with the *DataFlashBlock()* command. Issuing a 0x01, 0x02, or 0x03 with this command causes the corresponding information block (A, B, or C, respectively) to be transferred to the command space 0x40...0x5f for editing or reading by the system. Upon successful writing of checksum information to *BlockDataChecksum()*, the modified block is returned to data flash. **Note:** **Manufacturer Info Block A** is read-only when in SEALED mode.

### 4.4 ACCESS MODES

The bq27501 provides three security modes (FULL ACCESS, UNSEALED, and SEALED) that control data flash access permissions, according to [Table 4-6](#). *Data Flash* refers to those data flash locations, specified in [Table 4-7](#), that are accessible to the user. *Manufacture Information* refers to the three 32-byte blocks.

**Table 4-6. Data Flash Access**

Security Mode	Data Flash	Manufacture Information
FULL ACCESS	R/W	R/W
UNSEALED	R/W	R/W
SEALED	None	R (A); R/W (B, C)

Although FULL ACCESS and UNSEALED modes appear identical, only FULL ACCESS allows the bq27501 to write access-mode transition keys.

### 4.5 SEALING/UNSEALING DATA FLASH

The bq27501 implements a key-access scheme to transition between SEALED, UNSEALED, and FULL-ACCESS modes. Each transition requires that a unique set of two keys be sent to the bq27501 via the *Control()* control command. The keys must be sent consecutively, with no other data being written to the *Control()* register between them. Note that to avoid conflict, the keys must be different from the codes presented in the *CNTL DATA* column of [Table 4-2](#) *Control()* subcommands.

When in SEALED mode, the CONTROL\_STATUS [SS] bit is set, but when the unseal keys are correctly received by the bq27501, the [SS] bit is cleared. When the full-access keys are correctly received, then the CONTROL\_STATUS [FAS] bit is cleared.

## System-Side Impedance Track™ Fuel Gauge

SLUS879A–OCTOBER 2008–REVISED JUNE 2009

www.ti.com

Both the sets of keys for each level are 2 bytes each in length and are stored in data flash. The unseal key (stored at **Unseal Key 0** and **Unseal Key 1**) and the full-access key (stored at **Full-Access Key 0** and **Full-Access Key 1**) can only be updated when in FULL-ACCESS mode. The order of the keys is **Key 1** followed by **Key 0**. The order of the bytes entered through the *Control()* command is the reverse of what is read from the part. For example, if the **Key 1** and **Key 0** of the **Unseal Key** read returns 0x1234 and 0x5678, then the *Control()* should supply 0x3412 and 0x7856 to unseal the part.

### 4.6 DATA FLASH SUMMARY

Table 4-7 summarizes the data flash locations available to the user, including their default, minimum, and maximum values.

**Table 4-7. Data Flash Summary**

Class	Subclass ID	Subclass	Offset	Name	Data Type	Min Value	Max Value	Default Value	Units
Configuration	2	Safety	0	OT Chg	I2	0	1200	550	0.1°C
Configuration	2	Safety	2	OT Chg Time	U1	0	60	2	s
Configuration	2	Safety	3	OT Chg Recovery	I2	0	1200	500	0.1°C
Configuration	2	Safety	5	OT Dsg	I2	0	1200	600	0.1°C
Configuration	2	Safety	7	OT Dsg Time	U1	0	60	2	s
Configuration	2	Safety	8	OT Dsg Recovery	I2	0	1200	550	0.1°C
Configuration	32	Charge Inhibit Config	0	Charge Inhibit Temp Low	I2	-400	1200	0	0.1°C
Configuration	32	Charge Inhibit Config	2	Charge Inhibit Temp High	I2	-400	1200	450	0.1°C
Configuration	32	Charge Inhibit Config	4	Temp Hys	I2	0	100	50	0.1°C
Configuration	34	Charge	2	Charging Voltage	I2	0	20,000	4200	mV
Configuration	34	Charge	4	Delta Temperature	I2	0	500	50	0.1°C
Configuration	34	Charge	6	Suspend Temperature Low	I2	-400	1200	-50	0.1°C
Configuration	34	Charge	8	Suspend Temperature High	I2	-400	1200	550	0.1°C
Configuration	36	Charge Termination	2	Taper Current	I2	0	1000	100	mA
Configuration	36	Charge Termination	4	Minimum Taper Charge	I2	0	1000	25	0.01mAh
Configuration	36	Charge Termination	6	Taper Voltage	I2	0	1000	100	mV
Configuration	36	Charge Termination	8	Current Taper Window	U1	0	60	40	s
Configuration	36	Charge Termination	11	FC Set %	I1	-1	100	100	%
Configuration	36	Charge Termination	12	FC Clear %	I1	-1	100	98	%
Configuration	48	Data	4	Initial Standby Current	I1	-128	0	-10	mA
Configuration	48	Data	5	Initial Max Load Current	I2	-32,767	0	-500	mA
Configuration	48	Data	7	CC Threshold	I2	100	32,767	900	mAh
Configuration	48	Data	10	Design Capacity	I2	0	65,535	1000	mAh
Configuration	48	Data	12	Device Name	S8	x	x	bq27501	-
Configuration	49	Discharge	0	SOC1 Set Threshold	U1	0	255	150	mAh
Configuration	49	Discharge	1	SOC1 Clear Threshold	U1	0	255	175	mAh
Configuration	49	Discharge	2	SOCF Set Threshold	U1	0	255	75	mAh
Configuration	49	Discharge	3	SOCF Clear Threshold	U1	0	255	100	mAh
System Data	57	Manufacturer Info	0-31	Block A [0-31]	H1	0x00	0xff	0x00	-
System Data	57	Manufacturer Info	32-63	Block B [0-31]	H1	0x00	0xff	0x00	-

Table 4-7. Data Flash Summary (continued)

Class	Subclass ID	Subclass	Offset	Name	Data Type	Min Value	Max Value	Default Value	Units
System Data	57	Manufacturer Info	64–95	Block C [0–31]	H1	0x00	0xff	0x00	–
Configuration	64	Registers	0	Operation Configuration	H2	0x0000	0xffff	0x0979	–
Configuration	64	Registers	2	Pack 0 Voltage	U2	0	4200	1070	mV
Configuration	64	Registers	4	Pack 1 Voltage	U2	0	4200	110	mV
Configuration	64	Registers	6	Pack V% Range 0	U1	0	100	20	%
Configuration	64	Registers	7	Pack V% Range 1	U1	0	100	20	%
Configuration	64	Registers	8	RID Pull-up Selection	I1	0x00	0xff	0x01	–
Configuration	68	Power	0	Flash Update OK Voltage	I2	0	4200	2800	mV
Configuration	68	Power	7	Sleep Current	I2	0	100	10	mA
Configuration	68	Power	16	Hibernate Current	U2	0	700	8	mA
Configuration	68	Power	18	Hibernate Voltage	U2	2400	3000	2550	mV
Fuel Gauging	80	IT Cfg	0	Load Select	U1	0	255	1	–
Fuel Gauging	80	IT Cfg	1	Load Mode	U1	0	255	0	–
Fuel Gauging	80	IT Cfg	48	Terminate Voltage	I2	–32,768	32,767	3000	mV
Fuel Gauging	80	IT Cfg	53	User Rate-mA	I2	0	9000	0	mA
Fuel Gauging	80	IT Cfg	55	User Rate-mW	I2	0	14,000	0	mW
Fuel Gauging	80	IT Cfg	57	Reserve Cap-mAh	I2	0	9000	0	mAh
Fuel Gauging	80	IT Cfg	59	Reserve Cap-mWh	I2	0	14,000	0	mWh
Fuel Gauging	81	Current Thresholds	0	Dsg Current Threshold	I2	0	2000	60	mA
Fuel Gauging	81	Current Thresholds	2	Chg Current Threshold	I2	0	2000	75	mA
Fuel Gauging	81	Current Thresholds	4	Quit Current	I2	0	1000	40	mA
Fuel Gauging	81	Current Thresholds	6	Dsg Relax Time	U2	0	8191	60	s
Fuel Gauging	81	Current Thresholds	8	Chg Relax Time	U1	0	255	60	s
Fuel Gauging	81	Current Thresholds	9	Quit Relax Time	U1	0	63	1	s
Fuel Gauging	82	State	0	IT Enable	H1	0x00	0xff	0x00	–
Fuel Gauging	82	State	1	Application Status	H1	0x00	0xff	0x00	–
Fuel Gauging	82	State	2	Qmax 0	I2	0	32,767	1000	mAh
Fuel Gauging	82	State	4	Cycle Count 0	U2	0	65,535	0	–
Fuel Gauging	82	State	6	Update Status 0	H1	0x00	0x03	0x00	–
Fuel Gauging	82	State	7	Qmax 1	I2	0	32767	1000	mAh
Fuel Gauging	82	State	9	Cycle Count 1	U2	0	65,535	0	–
Fuel Gauging	82	State	11	Update Status 1	H1	0x00	0x03	0x00	–
Fuel Gauging	82	State	16	Avg I Last Run	I2	–32,768	32,767	–300	mA
Fuel Gauging	82	State	18	Avg P Last Run	I2	–32,768	32,767	–1200	mAh
Default Ra Tables	87	Def0 Ra	0–18	See Note <sup>(1)</sup>					
Default Ra Tables	88	Def1 Ra	0–18						
Ra Tables	91	Pack0 Ra	0–18	See Note <sup>(1)</sup>					
Ra Tables	92	Pack1 Ra	0–18						
Ra Tables	93	Pack0 Rax	0–18						
Ra Tables	94	Pack1 Rax	0–18						

(1) Encoded battery profile information created by bqEASY™ software.

# System-Side Impedance Track™ Fuel Gauge

SLUS879A–OCTOBER 2008–REVISED JUNE 2009

www.ti.com

**Table 4-7. Data Flash Summary (continued)**

Class	Subclass ID	Subclass	Offset	Name	Data Type	Min Value	Max Value	Default Value	Units
Calibration	104	Data	0	CC Gain	F4 <sup>(2)</sup>	0.1	47	10 <sup>(3)</sup>	mΩ
Calibration	104	Data	4	CC Delta	F4 <sup>(2)</sup>	4.7	188	10 <sup>(3)</sup>	mΩ
Calibration	104	Data	8	CC Offset	I2	-2.4	2.4	-0.123 <sup>(3)</sup>	mV
Calibration	104	Data	10	Board Offset	I1	-128	127	0	mV
Calibration	104	Data	11	Int Temp Offset	I1	-128	127	0	0.1°C
Calibration	104	Data	12	Ext Temp Offset	I1	-128	127	0	0.1°C
Calibration	104	Data	13	Pack V Offset	I1	-128	127	0	0.1°C
Calibration	107	Current	1	Deadband	U1	0	255	5	mA
Security	112	Codes	0	Unseal Key 0	H2	0x0000	0xffff	0x3672	–
Security	112	Codes	2	Unseal Key 1	H2	0x0000	0xffff	0x0414	–
Security	112	Codes	4	Full-Access Key 0	H2	0x0000	0xffff	0xffff	–
Security	112	Codes	6	Full-Access Key 1	H2	0x0000	0xffff	0xffff	–

(2) Not IEEE floating point

(3) Display as the value EVSW displayed. Data Flash value is different.

## 5 FUNCTIONAL DESCRIPTION

### 5.1 FUEL GAUGING

The bq27501 measures the cell voltage, temperature, and current to determine battery SOC. The bq27501 monitors charge and discharge activity by sensing the voltage across a small-value resistor (5 mΩ to 20 mΩ typ.) between the SRP and SRN pins and in series with the cell. By integrating charge passing through a battery, the battery's SOC is adjusted during battery charge or discharge.

The total battery capacity is found by comparing states of charge before and after applying the load with the amount of charge passed. When an application load is applied, the impedance of the cell is measured by comparing the OCV obtained from a predefined function for present SOC with the measured voltage under load. Measurements of OCV and charge integration determine chemical state of charge and chemical capacity (Qmax). The initial Qmax values are taken from a cell manufacturers' data sheet multiplied by the number of parallel cells. It is also used for the value in **Design Capacity**. The bq27501 acquires and updates the battery-impedance profile during normal battery usage. It uses this profile, along with SOC and the Qmax value, to determine *FullChargeCapacity()* and *StateOfCharge()*, specifically for the present load and temperature. *FullChargeCapacity()* is reported as capacity available from a fully charged battery under the present load and temperature until *Voltage()* reaches the **Term Voltage**. *NominalAvailableCapacity()* and *FullAvailableCapacity()* are the uncompensated (less than C/20) versions of *RemainingCapacity()* and *FullChargeCapacity()* respectively.

The bq27501 has two flags accessed by the *Flags()* function that warn when a battery's SOC has fallen to critical levels. When *RemainingCapacity()* falls below the first capacity threshold, specified in **SOC1 Set Threshold**, the *[SOC1]* (*State of Charge Initial*) flag is set. The flag is cleared once *RemainingCapacity()* rises above **SOC1 Clear Threshold**. The bq27501's BAT\_LOW pin automatically reflects the status of the *[SOC1]* flag. All units are in mAh.

When *RemainingCapacity()* falls below the second capacity threshold, **SOCF Set Threshold**, the *[SOCF]* (*State of Charge Final*) flag is set, serving as a final discharge warning. Set **SOCF Set Threshold** = 0 to deactivate the feature. Similarly, when *RemainingCapacity()* rises above **SOCF Clear Threshold** and the *[SOCF]* flag has already been set, the *[SOCF]* flag is cleared. All units are in mAh.

### 5.2 IMPEDANCE TRACK™ VARIABLES

The bq27501 has several data flash variables that permit the user to customize the Impedance Track™ algorithm for optimized performance. These variables are dependent upon the power characteristics of the application as well as the cell itself.

### 5.2.1 Load Mode

*Load Mode* is used to select either the constant-current or constant-power model for the Impedance Track™ algorithm as used in **Load Select** (see **Load Select**). When **Load Mode** is 0, the *Constant Current* model is used (default). When 1, the *Constant Power* model is used. The [LDMD] bit of CONTROL\_STATUS reflects the status of **Load Mode**.

### 5.2.2 Load Select

**Load Select** defines the type of power or current model to be used to compute load-compensated capacity in the Impedance Track™ algorithm. If **Load Mode** = 0 (*Constant-Current*) then the options presented in Table 5-1 are available.

**Table 5-1. Constant-Current Model Used When Load Mode = 0**

LoadSelect Value	Current Model Used
0	Average discharge current from previous cycle: There is an internal register that records the average discharge current through each entire discharge cycle. The previous average is stored in this register.
1(default)	Present average discharge current: This is the average discharge current from the beginning of this discharge cycle until present time.
2	Average current: based on <b>AverageCurrent()</b>
3	Current: based off of a low-pass-filtered version of <b>AverageCurrent()</b> ( $\tau = 14$ s)
4	Design capacity / 5: C Rate based off of Design Capacity /5 or a C/5 rate in mA.
5	AtRate (mA): Use whatever current is in <b>AtRate()</b>
6	User_Rate-mA: Use the value in <i>User_Rate-mA</i> . This mode provides a completely user-configurable method.

If **Load Mode** = 1 (*Constant Power*) then the following options shown in Table 5-2 are available.

**Table 5-2. Constant-Power Model Used When Load Mode = 1**

LoadSelect Value	Power Model Used
0	Average discharge power from previous cycle: There is an internal register that records the average discharge power through each entire discharge cycle. The previous average is stored in this register.
1(default)	Present average discharge power: This is the average discharge power from the beginning of this discharge cycle until present time.
2	Average current $\times$ voltage: based off the <b>AverageCurrent()</b> and <b>Voltage()</b> .
3	Current $\times$ voltage: based off of a low-pass-filtered version of <b>AverageCurrent()</b> ( $\tau = 14$ s) and <b>Voltage()</b>
4	Design energy / 5: C Rate based off of Design Energy /5 or a C/5 rate in mA.
5	AtRate (10 mW): Use whatever value is in <b>AtRate()</b> .
6	User_Rate-10mW: Use the value in <i>User_Rate-10mW</i> . This mode provides a completely user-configurable method.

### 5.2.3 Reserve Cap-mAh

**Reserve Cap-mAh** determines how much actual remaining capacity exists after reaching 0 **RemainingCapacity()**, before **Terminate Voltage** is reached. A no-load rate of compensation is applied to this reserve.

### 5.2.4 Reserve Cap-mWh

**Reserve Cap-mWh** determines how much actual remaining capacity exists after reaching 0 **AvailableEnergy()**, before **Terminate Voltage** is reached. A no-load rate of compensation is applied to this reserve capacity.

### 5.2.5 Dsg Current Threshold

This register is used as a threshold by many functions in the bq27501 to determine if actual discharge current is flowing into or out of the cell. The default for this register is in Table 4-7, which should be sufficient for most applications. This threshold should be set low enough to be below any normal application load current but high enough to prevent noise or drift from affecting the measurement.

## System-Side Impedance Track™ Fuel Gauge

SLUS879A–OCTOBER 2008–REVISED JUNE 2009

www.ti.com

### 5.2.6 Chg Current Threshold

This register is used as a threshold by many functions in the bq27501 to determine if actual charge current is flowing into or out of the cell. The default for this register is in [Table 4-7](#), which should be sufficient for most applications. This threshold should be set low enough to be below any normal charge current but high enough to prevent noise or drift from affecting the measurement.

### 5.2.7 Quit Current, DSG Relax Time, CHG Relax Time, and Quit Relax Time

The **Quit Current** is used as part of the Impedance Track™ algorithm to determine when the bq27501 enters relaxation mode from a current-flowing mode in either the charge direction or the discharge direction. The value of *Quit Current* is set to a default value in [Table 4-7](#) and should be above the standby current of the system.

Either of the following criteria must be met to enter relaxation mode:

- $|AverageCurrent()| < |Quit\ Current|$  for **Dsg Relax Time**
- $|AverageCurrent()| < |Quit\ Current|$  for **Chg Relax Time**

After about 5 minutes in relaxation mode, the bq27501 attempts to take accurate OCV readings. An additional requirement of  $dV/dt < 4\ \mu V/s$  is required for the bq27501 to perform Qmax updates. These updates are used in the Impedance Track™ algorithms. It is critical that the battery voltage be relaxed during OCV readings to and that the current is not be higher than C/20 when attempting to go into relaxation mode.

**Quit Relax Time** specifies the minimum time required for *AverageCurrent()* to remain above the **QuitCurrent** threshold before exiting relaxation mode.

### 5.2.8 Qmax 0 and Qmax 1

Generically called *Qmax*, these dynamic variables contain the respective maximum chemical capacity of the active cell profiles, and are determined by comparing states of charge before and after applying the load with the amount of charge passed. They also correspond to capacity at a low rate of discharge, such as the C/20 rate. For high accuracy, this value is periodically updated by the bq27501 during operation. Based on the battery cell capacity information, the initial value of chemical capacity should be entered in the **Qmax n** field for each default cell profile. The Impedance Track™ algorithm updates these values and maintains them the associated actual cell profiles.

### 5.2.9 Update Status 0 and Update Status 1

Bit 0 (0x01) of the **Update Status n** registers indicates that the bq27501 has learned new Qmax parameters and is accurate. The remaining bits are reserved. Bit 0 is a status flag set by the bq27501. Bit 0 should not be modified except when creating a golden image file as explained in the application note [Preparing Optimized Default Flash Constants for specific Battery Types \(SLUA334\)](#). Bit 0 is updated as needed by the bq27501.

### 5.2.10 Avg I Last Run

The bq27501 logs the current averaged from the beginning to the end of each discharge cycle. It stores this average current from the previous discharge cycle in this register. This register should not be modified. It is only updated by the bq27501 when required.

### 5.2.11 Avg P Last Run

The bq27501 logs the power averaged from the beginning to the end of each discharge cycle. It stores this average power from the previous discharge cycle in this register. To get a correct average power reading, the bq27501 continuously multiplies instantaneous current times Voltage( ) to get power. It then logs this data to derive the average power. This register should not be modified. It is only updated by the bq27501 when required.

### 5.2.12 Delta Voltage

The bq27501 stores the maximum difference of *Voltage()* during short load spikes and normal load, so the Impedance Track™ algorithm can calculate remaining capacity for pulsed loads. It is not recommended to change this value.

### 5.2.13 Default Ra and Ra Tables

These tables contain encoded data and, with the exception of the **Default Ra Tables**, are automatically updated during device operation. No user changes should be made except for reading/writing the values from a pre-learned pack (part of the process for creating golden image files).

## 5.3 DETAILED DESCRIPTION OF DEDICATED PINS

### 5.3.1 The Operation Configuration Register

Some bq27501 pins are configured via the **Operation Configuration** data flash register, as indicated in [Table 5-3](#). This register is programmed/read via the methods described in [Section 4.2.1, Accessing the Data Flash](#). The register is located at subclass = 64, offset = 0.

**Table 5-3. Operation Configuration Bit Definition**

Operation Cfg	bit7	bit6	bit5	bit4	bit3	bit2	bit1	bit0
High byte	RESCAP	BATG_OVR	–	PFC_CFG1	PFC_CFG0	IWAKE	RSNS1	RSNS0
Low byte	GNDSEL	IDSELEN	SLEEP	RMFCC	BATL_POL	BATG_POL	–	TEMPS

RESCAP = No-load rate of compensation is applied to the reserve capacity calculation. True when set. Default is 0.

BATG\_OVR =  $\overline{\text{BAT\_GD}}$  override bit. If the gauge enters Hibernate only due to the cell voltage, the  $\overline{\text{BAT\_GD}}$  will not negate. True when set. Default is 0.

PFC\_CFG1/PFC\_CFG0 = Pin function code (PFC) mode selection: PFC 0, 1, or 2 selected by 0/0, 0/1, or 1/0, respectively. Default is PFC 1 (0/1).

IWAKE/RSNS1/RSNS0 = These bits configure the current wake function (see [Table 5-4](#)). Default is 0/0/1.

GNDSEL = The ADC ground selection control. The  $V_{SS}$  (Pin 6) is selected as the ground referenced when the bit is clear. Pin 7 is selected when the bit is set. Default is 1.

IDSELEN = Enables cell profile selection feature. True when set. Default is 1.

SLEEP = The fuel gauge can enter sleep, if operating conditions allow. True when set. Default is 1.

RMFCC = RM is updated with the value from FCC, on valid charge termination. True when set. Default is 1.

BATL\_POL =  $\overline{\text{BAT\_LOW}}$  pin is active-high. True when set. Default is 1.

BATG\_POL =  $\overline{\text{BAT\_GD}}$  pin is active-low. True when cleared. Default is 0.

TEMPS = Selects external thermistor for Temperature( ) measurements. True when set. Default is 1.

### 5.3.2 Pin Function Code Descriptions

The bq27501 has three possible pin-function variations that can be selected in accordance with the circuit architecture of the end application. Each variation has been assigned a pin function code, or PFC.

When the PFC is set to 0, only the bq27501 measures battery temperature under discharge and relaxation conditions. The charger does not receive any information from the bq27501 about the temperature readings, and therefore operates open-loop with respect to battery temperature.

A PFC of 1 is like a PFC of 0, except temperature is also monitored during battery charging. If charging temperature falls outside of the preset range defined in data flash, a charger can be disabled via the  $\overline{\text{BAT\_GD}}$  pin until cell temperature recovers. See [Section 5.6.2, Charge Inhibit](#), for additional details.

Finally when the PFC is set to 2, the battery thermistor can be shared between the fuel gauge and the charger. The charger has full usage of the thermistor during battery charging. The fuel gauge uses the thermistor exclusively during discharge and battery relaxation.

The PFC is specified in **Operation Configuration [PFC\_CFG1, PFC\_CFG0]**. The default is PFC = 1.

## System-Side Impedance Track™ Fuel Gauge

SLUS879A–OCTOBER 2008–REVISED JUNE 2009

www.ti.com

### 5.3.3 BAT\_LOW Pin

The BAT\_LOW pin provides a system processor with an electrical indicator of battery status. The signaling on the BAT\_LOW pin follows the status of the [SOC1] bit in the *Flags( )* register. Note that the polarity of the BAT\_LOW pin can be inverted via the [BATL\_POL] bit of **Operation Configuration**.

### 5.3.4 Power Path Control With the BAT\_GD Pin

The bq27501 must operate in conjunction with other electronics in a system appliance, such as chargers or other ICs and application circuits that draw appreciable power. After a battery is inserted into the system, there should be no charging or discharging current higher than C/20, so that an accurate OCV can be read. The OCV is used for helping determine which battery profile to use, as it constitutes part of the battery impedance measurement.

When a battery is inserted into a system, the Impedance Track™ algorithm requires that no charging of the battery takes place and that any discharge is limited to less than C/20—these conditions are sufficient for the fuel gauge to take an accurate OCV reading. To disable these functions, the  $\overline{\text{BAT\_GD}}$  pin is merely set negated from the default setting. Once an OCV reading has been made, the  $\overline{\text{BAT\_GD}}$  pin is asserted, thereby enabling battery charging and regular discharge of the battery. The **Operation Configuration [BATG\_POL]** bit can be used to set the polarity of the battery good signal, should the default configuration need to be changed.

The flowchart of [Figure 5-1](#) details how the  $\overline{\text{BAT\_GD}}$  pin functions in the context of battery insertion and removal, as well as NORMAL vs SLEEP modes.

In PFC 1, the  $\overline{\text{BAT\_GD}}$  pin is also used to disable battery charging when the bq27501 reads battery temperatures outside the range defined by [**Charge Inhibit Temp Low, Charge Inhibit Temp High**]. The  $\overline{\text{BAT\_GD}}$  line is returned to *low* once temperature falls within the range [**Charge Inhibit Temp Low + Temp Hys, Charge Inhibit Temp High – Temp Hys**].

### 5.3.5 Battery Detection Using the BI/TOUT Pin

During power-up or hibernate activities, or any other activity where the bq27501 must determine whether a battery is connected or not, the fuel gauge applies a test for battery presence. First, the BI/TOUT pin is put into high-Z status. The weak 1.8-M $\Omega$  pullup resistor keeps the pin high while no battery is present. When a battery is inserted (or is already inserted) into the system device, the BI/TOUT pin is pulled low. This state is detected by the fuel gauge, which polls this pin every second when the gauge has power. A *battery disconnected* status is assumed when the bq27501 reads a thermistor voltage that is near 2.5 V.

## 5.4 TEMPERATURE MEASUREMENT

The bq27501 measures battery temperature via its TS input, in order to supply battery temperature status information to the fuel gauging algorithm and charger-control sections of the gauge. Alternatively, it can also measure internal temperature via its on-chip temperature sensor, but only if the [TEMPS] bit of the **Operation Configuration** register is cleared.

Regardless of which sensor is used for measurement, a system processor can request the current battery temperature by calling the *Temperature( )* function (see [Section 4.1.1, Standard Data Commands](#), for specific information).

The bq27501 external temperature sensing is optimized with the use of a high accuracy negative temperature coefficient (NTC) thermistor with  $R_{25} = 10.0\text{K}\Omega \pm 1\%$  and  $B_{25/85} = 3435\text{K} \pm 1\%$  (such as Semitec NTC 103AT). The bq27501 can also be configured to use its internal temperature sensor. When an external thermistor is used, a 18.2k pull up resistor between BT/TOUT and TS pins is also required. Additional circuit information for connecting this thermistor to the bq27501 is shown in [Section 8, Reference Schematic](#).

## 5.5 OVERTEMPERATURE INDICATION

### 5.5.1 Overtemperature: Charge

If during charging, *Temperature()* reaches the threshold of **OT Chg** for a period of **OT Chg Time** and *AverageCurrent()* > **Chg Current Threshold**, then the [OTC] bit of *Flags()* is set. When *Temperature()* falls to **OT Chg Recovery**, the [OTC] of *Flags()* is reset.

If **OT Chg Time** = 0, then the feature is completely disabled.

### 5.5.2 Overtemperature: Discharge

If during discharging, *Temperature()* reaches the threshold of **OT Dsg** for a period of **OT Dsg Time**, and *AverageCurrent()* ≤ **-Dsg Current Threshold**, then the [OTD] bit of *Flags()* is set. When *Temperature()* falls to **OT Dsg Recovery**, the [OTD] bit of *Flags()* is reset.

If **OT Dsg Time** = 0, then feature is completely disabled.

## 5.6 CHARGING AND CHARGE-TERMINATION INDICATION

### 5.6.1 Detecting Charge Termination

For proper bq27501 operation, the cell charging voltage must be specified by the user. The default value for this variable is **Charging Voltage** = 4200 mV.

The bq27501 detects charge termination when (1) during 2 consecutive periods of **Current Taper Window**, the *AverageCurrent()* is < **Taper Current**, (2) during the same periods, the accumulated change in capacity > 0.25 mAh / **Current Taper Window**, and (3) *Voltage()* > **Charging Voltage – Taper Voltage**. When this occurs, the [CHG] bit of *Flags()* is cleared. Also, if the [RMFCC] bit of **Operation Configuration** is set, then *RemainingCapacity()* is set equal to *FullChargeCapacity()*.

### 5.6.2 Charge Inhibit

When PFC = 1, the bq27501 can indicate when battery temperature has fallen below or risen above predefined thresholds (**Charge Inhibit Temp Low** and **Charge Inhibit Temp High**, respectively). In this mode, the BAT\_GD line is made *high* to indicate this condition then returned to its *low* state, once battery temperature returns to the range [**Charge Inhibit Temp Low + Temp Hys**, **Charge Inhibit Temp High – Temp Hys**].

When PFC = 0 or 2, the bq27501 must be queried by the system in order to determine the battery temperature. At that time, the bq27501 samples the temperature. This saves battery energy when operating from battery, as periodic temperature updates are avoided during charging mode.

## 5.7 POWER MODES

The bq27501 has different power modes: NORMAL, SLEEP+, SLEEP, HIBERNATE, and BAT INSERT CHECK. In NORMAL mode, the bq27501 is fully powered and can execute any allowable task. In SLEEP+ and SLEEP mode, the fuel gauge exists in a reduced-power state, periodically taking measurements and performing calculations. In HIBERNATE mode, the fuel gauge is in its lowest power state, but can be woken up by communication activity or certain I/O activity. Finally, the BAT INSERT CHECK mode is a powered-up, but low-power halted state, where the bq27501 resides when no battery is inserted into the system.

The relationship between these modes is shown in [Figure 5-1](#).

### 5.7.1 NORMAL MODE

The fuel gauge is in NORMAL mode when not in any other power mode. During this mode, *AverageCurrent()*, *Voltage()* and *Temperature()* measurements are taken, and the interface data set is updated. Decisions to change states are also made. This mode is exited by activating a different power mode.

## System-Side Impedance Track™ Fuel Gauge

SLUS879A–OCTOBER 2008–REVISED JUNE 2009

www.ti.com

Because the gauge consumes the most power in NORMAL mode, the Impedance Track™ algorithm minimizes the time the fuel gauge remains in this mode.

### 5.7.2 SLEEP+ MODE

Compared to the SLEEP mode, SLEEP+ mode has the high frequency oscillator in operation. The communication delay could be eliminated. The SLEEP+ is entered automatically if the feature is enabled (**Operation Configuration [SNOOZE]** = 1) and  $AverageCurrent()$  is below the programmable level Sleep Current. During SLEEP+ mode, the bq27501 periodically takes data measurements and updates its data set. However, a majority of its time is spent in an idle condition. The bq27500 exits SLEEP+ if any entry condition is broken, specifically when (1) any communication activity with the gauge, or (2)  $AverageCurrent()$  rises above **Sleep Current**, or (3) a current in excess of I<sub>WAKE</sub> through R<sub>SENSE</sub> is detected.

### 5.7.3 SLEEP MODE

SLEEP mode is entered automatically if the feature is enabled (**Operation Configuration [SLEEP]** = 1) and  $AverageCurrent()$  is below the programmable level **Sleep Current**. Once entry into SLEEP mode has been qualified, but prior to entering it, the bq27501 performs an Coulomb Counter autocalibration to minimize offset.

During SLEEP mode, the bq27501 periodically takes data measurements and updates its data set. However, a majority of its time is spent in an idle condition.

The bq27501 exits SLEEP if any entry condition is broken, specifically when (1)  $AverageCurrent()$  rises above **Sleep Current**, or (2) a current in excess of I<sub>WAKE</sub> through R<sub>SENSE</sub> is detected.

In the event that a battery is removed from the system while a charger is present (and powering the gauge), Impedance Track™ updates are not necessary. Hence, the fuel gauge enters a state that checks for battery insertion and does not continue executing the Impedance Track™ algorithm.

While in SLEEP mode, the fuel gauge can suspend serial communications as much as 4ms by holding the SCL line low. This delay is necessary correctly process host communication, since the fuel gauge processor is mostly halted while in SLEEP mode.

### 5.7.4 BAT-INSERT-CHECK MODE

This mode is a halted-CPU state that occurs when an adapter or other power source is present to power the bq27501 (and system), yet no battery has been detected. When battery insertion is detected, a series of initialization activities begins, which includes: OCV measurement, asserting the BAT\_GD pin, and selecting the appropriate battery profiles. The initialization time is less than 2 seconds.

Some commands issued by a system processor can be processed while the bq27501 is halted in this mode. The gauge wakes up to process the command, then returns to the halted state awaiting battery insertion.

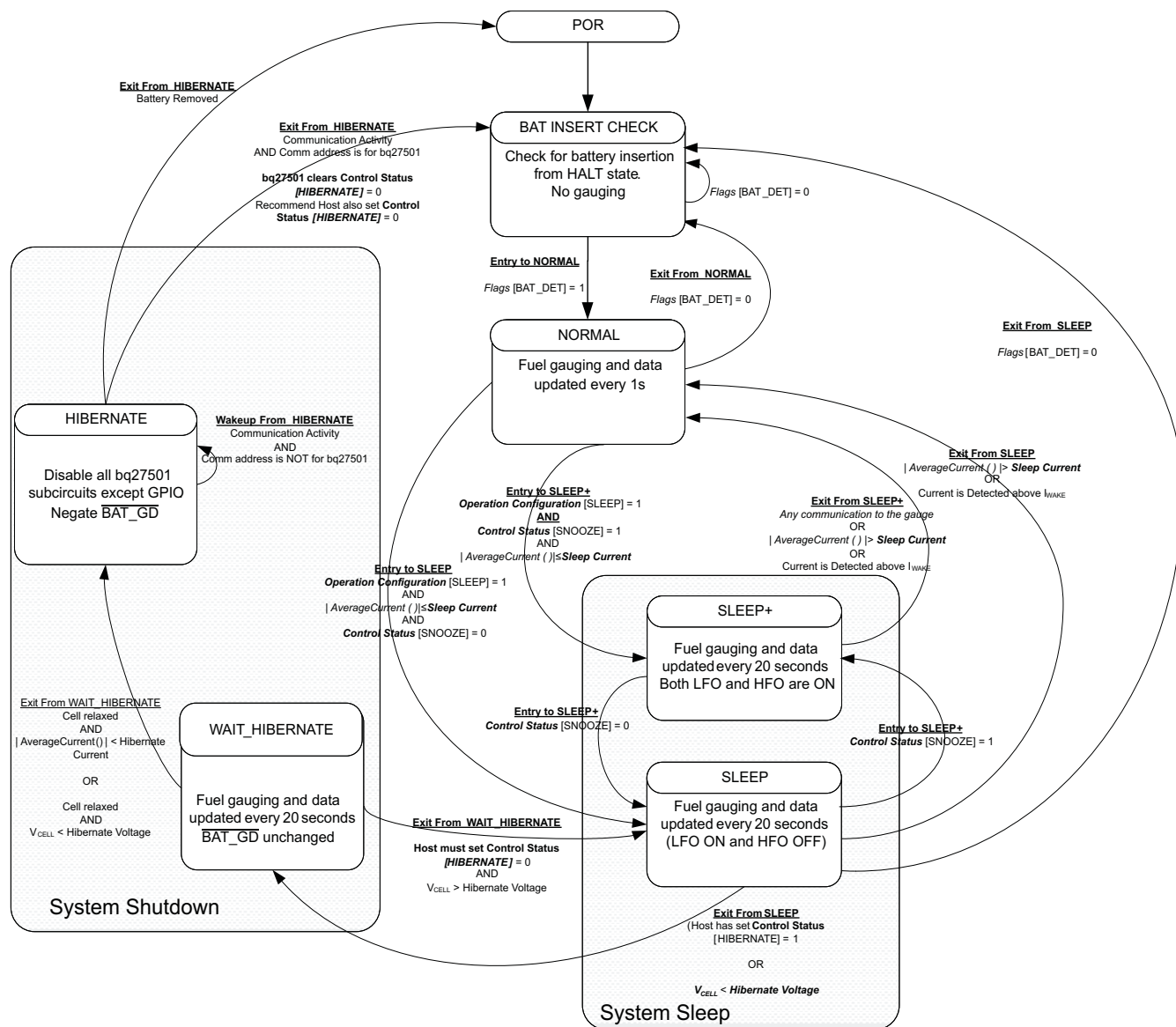

Figure 5-1. Power Mode Diagram

### 5.7.5 HIBERNATE MODE

HIBERNATE mode should be used when the system equipment needs to enter a low-power state, and minimal gauge power consumption is required. This mode is ideal when a system equipment is set to its own HIBERNATE, SHUTDOWN, or OFF modes.

The fuel gauge can enter HIBERNATE due to either low cell voltage or low load current.

- HIBERNATE due to the cell voltage. When the cell voltage drops below the Hibernate Voltage and a valid OCV measurement has been taken, the fuel gauge enters HIBERNATE mode. The [HIBERNATE] bit of the CONTROL register has no impact for the fuel gauge to enter the HIBERNATE mode.

## System-Side Impedance Track™ Fuel Gauge

SLUS879A–OCTOBER 2008–REVISED JUNE 2009

www.ti.com

- Hibernate due to the load current. If the load current drops to certain level, the fuel gauge should also enter low power mode. When the fuel gauge enters the HIBERNATE mode due to the load current, the [HIBERNATE] bit of the CONTROL\_STATUS register must be set. The gauge waits to enter HIBERNATE mode until it has taken a valid OCV measurement and the magnitude of the average cell current has fallen below **Hibernate Current**. The gauge remains in HIBERNATE mode until the system issues a direct I<sup>2</sup>C command to the gauge or a POR occurs. I<sup>2</sup>C communication that is not directed to the gauge does not wake the gauge.

During the HIBERNATE mode the  $\overline{\text{BAT\_GD}}$  is negated (no battery charging/discharging). This prevents a charger application from inadvertently charging the battery before an OCV reading can be taken. It is the system's responsibility to wake the bq27501 after it has gone into HIBERNATE mode. After waking, the gauge can proceed with the initialization of the battery information (OCV, profile selection, etc.)

### 5.8 POWER CONTROL

#### 5.8.1 RESET FUNCTIONS

When the bq27501 detects software reset ([RESET] bit of Control()) it increments the reset counter. This information is accessible by issuing the command Control() function with the RESET\_DATA subcommand.

#### 5.8.2 WAKE-UP COMPARATOR

The wake up comparator is used to indicate a change in cell current while the bq27501 is in SLEEP mode. **Operation Configuration** uses bits [RSNS1–RSNS0] to set the sense resistor selection. **Operation Configuration** also uses the [IWAKE] bit to select one of two possible voltage threshold ranges for the given sense resistor selection. An internal interrupt is generated when the threshold is reached in either the charge or discharge direction. Setting both [RSNS1] and [RSNS0] to 0 disables this feature.

Table 5-4. I<sub>WAKE</sub> Threshold Settings<sup>(1)</sup>

RSNS1	RSNS0	IWAKE	V <sub>th</sub> (SRP–SRN)
0	0	0	Disabled
0	0	1	Disabled
0	1	0	1.0 mV or –1.0 mV
0	1	1	2.2 mV or –2.2 mV
1	0	0	2.2 mV or –2.2 mV
1	0	1	4.6 mV or –4.6 mV
1	1	0	4.6 mV or –4.6 mV
1	1	1	9.8 mV or –9.8 mV

(1) The actual resistance value vs. the setting of the sense resistor is not important, just the actual voltage threshold when calculating the configuration. The voltage thresholds are typical values under room temperature.

#### 5.8.3 FLASH UPDATES

Data Flash can only be updated if Voltage() ≥ **Flash Update OK Voltage**. Flash programming current can cause an increase in LDO dropout. The value of **Flash Update OK Voltage** should be selected such that the bq27501 V<sub>CC</sub> voltage does not fall below its minimum of 2.4 V during Flash write operations.

## 5.9 AUTOCALIBRATION

The bq27501 provides an autocalibration feature that measures the voltage offset error across SRP and SRN as operating conditions change. It subtracts the resulting offset error from normal sense resistor voltage,  $V_{SR}$ , for maximum measurement accuracy.

Autocalibration of the Coulomb Counter begins on entry to SLEEP mode, except if  $Temperature( ) \leq 5^{\circ}\text{C}$  or  $Temperature( ) \geq 45^{\circ}\text{C}$ .

The fuel gauge also performs a single offset when (1) the condition of  $AverageCurrent( ) \leq 100 \text{ mA}$  and (2) {voltage change since last offset calibration  $\geq 256 \text{ mV}$ } or {temperature change since last offset calibration is greater than  $8^{\circ}\text{C}$  for  $\geq 60 \text{ s}$ }.

Capacity and current measurements continue at the last measured rate during the offset calibration when these measurements cannot be performed. If the battery voltage drops more than 32 mV during the offset calibration, the load current has likely increased considerably; hence, the offset calibration is aborted.

## 6 APPLICATION-SPECIFIC INFORMATION

### 6.1 BATTERY PROFILE STORAGE AND SELECTION

#### 6.1.1 Common Profile Aspects

When a battery pack is removed from host equipment that implements the bq27501, the fuel gauge maintains some of the battery information in case the battery is re-inserted. This way, the Impedance Track™ algorithm has a means of recovering battery-status information, thereby maintaining good state-of-charge (SOC) estimates.

Two default battery profiles are available to store battery information. They are used to provide the Impedance Track™ algorithm with the default information on two possible battery types expected to be used with the end-equipment. These default profiles can be used to support batteries of different chemistry, same chemistry but different capacities, or same chemistry but different models. Default profiles are programmed by the end-equipment manufacturer.

In addition to the default profiles, the bq27501 maintains two profiles PACK0 and PACK1. These tables hold *dynamic* battery data, and keep track of the status for up to two of the most recent batteries used. In most cases, the bq27501 can manage the information on two removable battery packs.

#### 6.1.2 Activities Upon Pack Insertion

##### 6.1.2.1 First OCV and Impedance Measurement

At power up, the  $\overline{\text{BAT\_GD}}$  pin is inactive, so that the host cannot obtain power from the battery (this depends on the actual implementation). In this state, the battery is put in an open-circuit condition. Next, the bq27501 measures its first open-circuit voltage (OCV) via the BAT pin. From the OCV(SOC) table, the SOC of the inserted battery is found. Then the  $\overline{\text{BAT\_GD}}$  pin is made active, and the impedance of the inserted battery is calculated from the measured voltage and the load current:  $Z(\text{SOC}) = [\text{OCV}(\text{SOC}) - V] / I$ . This impedance is compared with the impedance of the dynamic profiles, **Pack $n$** , and the default profiles, **Def $n$** , for the same SOC (the letter  $n$  depicts either a 0 or 1).

#### 6.1.3 Reading Application Status

The **Application Status** data flash location contains cell profile status information, and can be read using the  $ApplicationStatus( )$  extended command (0x6a). The bit configuration of this function/location is shown in [Table 6-1](#).

## System-Side Impedance Track™ Fuel Gauge

SLUS879A–OCTOBER 2008–REVISED JUNE 2009

www.ti.com

**Table 6-1. ApplicationStatus( ) Bit Definitions.**

Application Configuration	bit7	bit6	bit5	bit4	bit3	bit2	bit1	bit0
Byte	—	—	—	—	—	—	—	LU_PROF

LU\_PROF = Last profile used by fuel gauge. Pack0 last used when cleared. Pack1 last used when set. Default is 0.

## 6.2 APPLICATION-SPECIFIC FLOW AND CONTROL

### 6.2.1 Battery With Resistor ID

The bq27501 can manage the information of up to two battery packs. For a given pack connected to the fuel gauge, the identity of the battery is determined by a combination of (1) reading the pack ID resistor, (2) measuring the impedance of the currently connected pack, and (3) remembering which pack characteristics were most recently used by the gauge.

A battery-pack ID resistor should connect to the RID pin of the fuel gauge. Either  $A\text{-}\Omega$  or  $B\text{-}\Omega$  resistor values should be used to indicate the battery type. If a battery connection is detected, then bq27501 measures the voltage developed at RID. If the voltage is **Pack 0 Voltage**, then it is identified as battery pack with  $A$  resistor and the bq27501 uses the **Pack0** profile. If the voltage measured is **Pack 1 Voltage**, then it is identified as battery pack with  $B$  resistor and the bq27501 uses **Pack1** profile.

The internal pull up of the RID pin is specified by the RID Pull-up Select. The meaning of 0, 1, 2 mean no pull up, a weak pull-up and a strong pull-up, respectively. The default value is 1, which means a weak pull-up is used. There is a P-channel Fet between the Vcc and the RID pin to realize the weak pull-up.

The measurement window around each threshold is specified by **Pack V% Range 0** or Pack V% Range 1 respectively, which indicates the positive or negative deviation around each level. With the recommended 300  $\Omega$  on board filter resistor, Choosing RID values of 8 k $\Omega$  and 500  $\Omega$  for  $A$  and  $B$ , respectively when the weak pull up is used, correspond to **Pack 0 Voltage** and **Pack 1 Voltage** threshold levels of 1070 mV and 110 mV, respectively. The **Pack V% Range 1** could be a higher percentage value as long as the two threshold voltages do not have overlap.

#### 6.2.1.1 Profile Selection

When a battery pack is inserted to the host for the first time, both the Packn profiles are copies of the respective Defn profiles. Each Packn profile has an additional field called *Parent* to indicate the Defn profile from which it was initialized. Once the impedance of a newly inserted pack has been measured the gauge FW will select a Packn profile to use for tracking impedance changes of that pack.

Assuming the bq27501 has selected **Pack0** for the first pack used in the system, if the pack is replaced with a second pack having the same resistor ID as the first, cell impedance is measured after pack detection as explained in [Section 6.1.2.1, First OCV and Impedance Measurement](#). This impedance is compared with the **Pack0** and **Def0** profiles. If it matches the **Pack0** impedance, then the **Pack0** profile is used (this situation indicates the last pack used was re-inserted). If not, a new pack is assumed, so the bq27501 copies the **Def0** profile into the **Pack1** profile, and **Pack1** is made the active profile. This feature helps support accurate fuel gauging for two batteries with the same resistor ID. The logic behind this profile selection process is also applied to the case where the first pack inserted causes the bq27501 to copy the **Def1** profile into **Pack1**.

If both the cell profiles have been in use (indicating two different battery packs have been used in the system) and a battery is inserted, the bq27501 chooses the correct **Packn** profile to re-write. This decision is based on the resistor ID, the impedance of the inserted battery, and the fact that the last-used battery profile should not be overwritten.

## 7 COMMUNICATIONS

### 7.1 I<sup>2</sup>C INTERFACE

The 27500/1 supports the standard I<sup>2</sup>C read, incremental read, quick read, one byte write, and incremental write functions. The 7 bit device address (ADDR) is the most significant 7 bits of the hex address and is fixed as 1010101. The 8-bit device address will therefore be 0xAA or 0xAB for write or read, respectively.

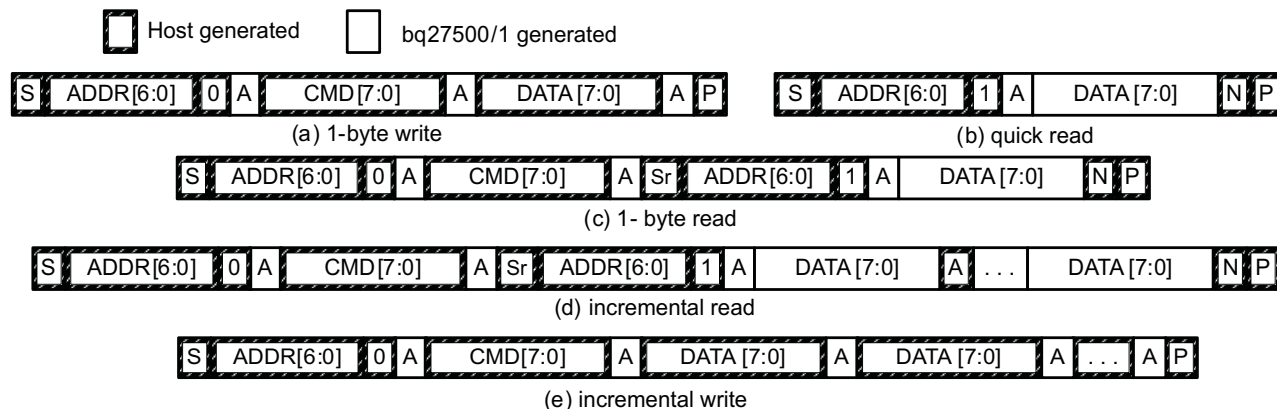

(S = Start, Sr = Repeated Start, A = Acknowledge, N = No Acknowledge, and P = Stop).

The “quick read” returns data at the address indicated by the address pointer. The address pointer, a register internal to the I<sup>2</sup>C communication engine, will increment whenever data is acknowledged by the bq27501 or the I<sup>2</sup>C master. “Quick writes” function in the same manner and are a convenient means of sending multiple bytes to consecutive command locations (such as two-byte commands that require two bytes of data)

The following command sequences are not supported:

Attempt to write a read-only address (NACK after data sent by master):

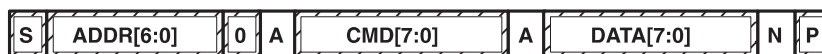

Attempt to read an address above 0x6B (NACK command):



The I<sup>2</sup>C engine will release both SDA and SCL if the I<sup>2</sup>C bus is held low for  $t_{(BUSERR)}$ . If the bq27501 was holding the lines, releasing them will free the master to drive the lines. If an external condition is holding either of the lines low, the I<sup>2</sup>C engine will enter the low power sleep mode.

### 7.2 I<sup>2</sup>C TIME OUT

The I<sup>2</sup>C engine will release both SDA and SCL if the I<sup>2</sup>C bus is held low for about 2 seconds. If the bq27501 was holding the lines, releasing them will free for the master to drive the lines. If an external condition is holding either of the lines low, the I<sup>2</sup>C engine will enter the low power sleep mode.

## System-Side Impedance Track™ Fuel Gauge

SLUS879A–OCTOBER 2008–REVISED JUNE 2009

[www.ti.com](http://www.ti.com)

### 7.3 I<sup>2</sup>C Command Waiting Time

To make sure the correct results of a command with the 400KHz I2C operation, a proper waiting time should be added between issuing command and reading results. For subcommands, the following diagram shows the waiting time required between issuing the control command the reading the status with the exception of checksum command. A 100ms waiting time is required between the checksum command and reading result. For read-write standard command, a minimum of 2 seconds is required to get the result updated. For read-only standard commands, there is no waiting time required, but the host should not issue all standard commands more than two times per second. Otherwise, the gauge could result in a reset issue due to the expiration of the watchdog timer. The I2C clock stretch could happen in a typical application. A maximum 80ms clock stretch could be observed during the flash updates.

## 8 REFERENCE SCHEMATICS

### 8.1 SCHEMATIC

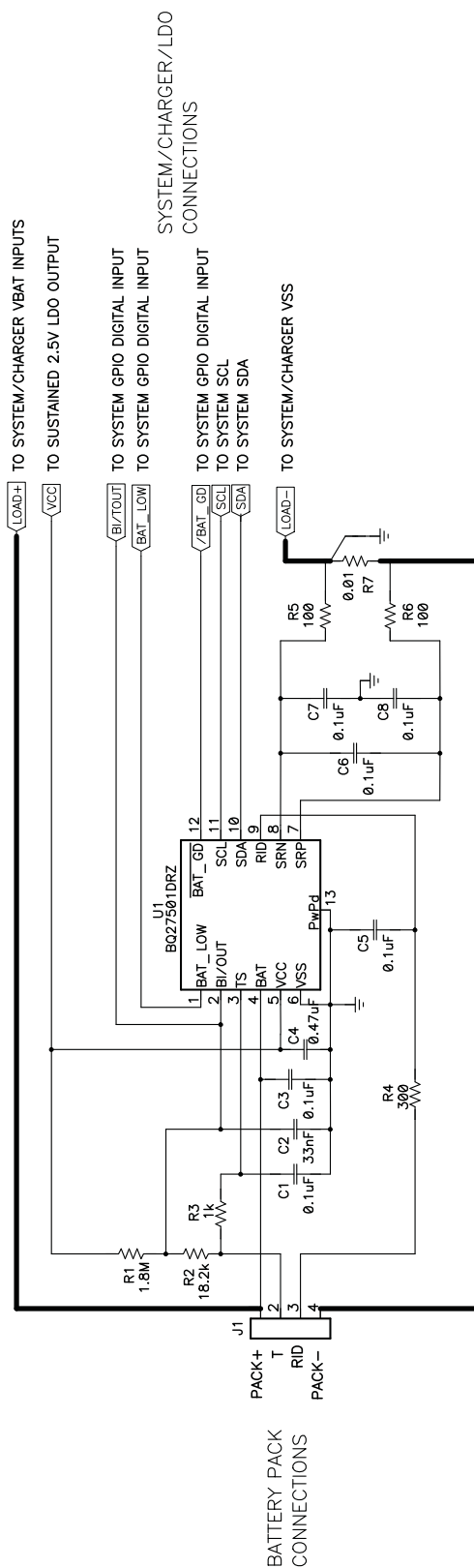

**PACKAGING INFORMATION**

Orderable Device	Status <sup>(1)</sup>	Package Type	Package Drawing	Pins	Package Qty	Eco Plan <sup>(2)</sup>	Lead/Ball Finish	MSL Peak Temp <sup>(3)</sup>
BQ27501DRZR	ACTIVE	SON	DRZ	12	3000	Green (RoHS & no Sb/Br)	CU NIPDAU	Level-2-260C-1 YEAR
BQ27501DRZT	ACTIVE	SON	DRZ	12	250	Green (RoHS & no Sb/Br)	CU NIPDAU	Level-2-260C-1 YEAR

<sup>(1)</sup> The marketing status values are defined as follows:

**ACTIVE:** Product device recommended for new designs.

**LIFEBUY:** TI has announced that the device will be discontinued, and a lifetime-buy period is in effect.

**NRND:** Not recommended for new designs. Device is in production to support existing customers, but TI does not recommend using this part in a new design.

**PREVIEW:** Device has been announced but is not in production. Samples may or may not be available.

**OBsolete:** TI has discontinued the production of the device.

<sup>(2)</sup> Eco Plan - The planned eco-friendly classification: Pb-Free (RoHS), Pb-Free (RoHS Exempt), or Green (RoHS & no Sb/Br) - please check <http://www.ti.com/productcontent> for the latest availability information and additional product content details.

**TBD:** The Pb-Free/Green conversion plan has not been defined.

**Pb-Free (RoHS):** TI's terms "Lead-Free" or "Pb-Free" mean semiconductor products that are compatible with the current RoHS requirements for all 6 substances, including the requirement that lead not exceed 0.1% by weight in homogeneous materials. Where designed to be soldered at high temperatures, TI Pb-Free products are suitable for use in specified lead-free processes.

**Pb-Free (RoHS Exempt):** This component has a RoHS exemption for either 1) lead-based flip-chip solder bumps used between the die and package, or 2) lead-based die adhesive used between the die and leadframe. The component is otherwise considered Pb-Free (RoHS compatible) as defined above.

**Green (RoHS & no Sb/Br):** TI defines "Green" to mean Pb-Free (RoHS compatible), and free of Bromine (Br) and Antimony (Sb) based flame retardants (Br or Sb do not exceed 0.1% by weight in homogeneous material)

<sup>(3)</sup> MSL, Peak Temp. -- The Moisture Sensitivity Level rating according to the JEDEC industry standard classifications, and peak solder temperature.

**Important Information and Disclaimer:**The information provided on this page represents TI's knowledge and belief as of the date that it is provided. TI bases its knowledge and belief on information provided by third parties, and makes no representation or warranty as to the accuracy of such information. Efforts are underway to better integrate information from third parties. TI has taken and continues to take reasonable steps to provide representative and accurate information but may not have conducted destructive testing or chemical analysis on incoming materials and chemicals. TI and TI suppliers consider certain information to be proprietary, and thus CAS numbers and other limited information may not be available for release.

In no event shall TI's liability arising out of such information exceed the total purchase price of the TI part(s) at issue in this document sold by TI to Customer on an annual basis.

## TAPE AND REEL INFORMATION

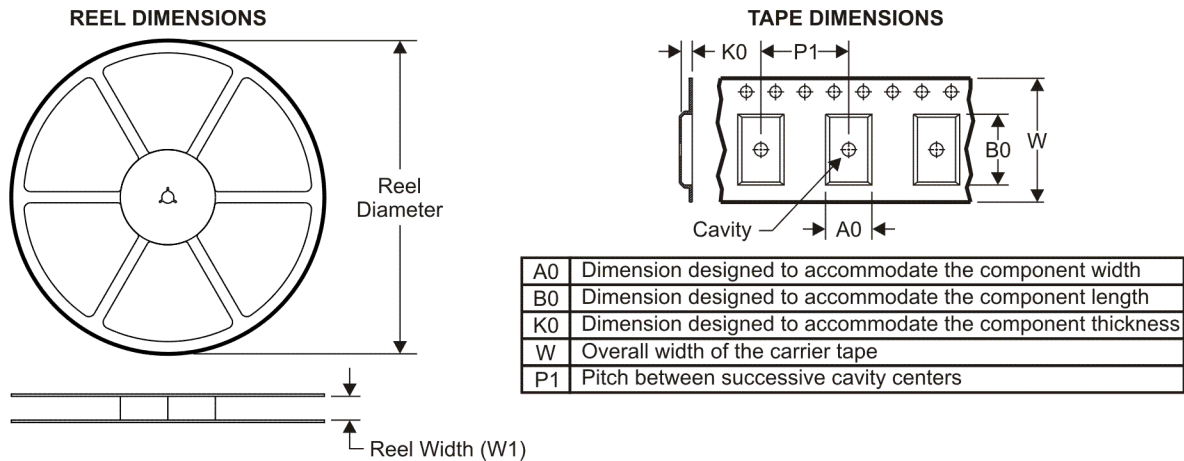

### QUADRANT ASSIGNMENTS FOR PIN 1 ORIENTATION IN TAPE

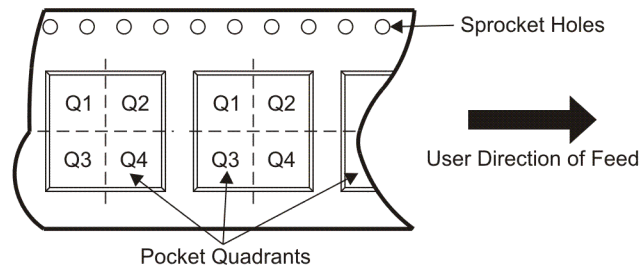

\*All dimensions are nominal

Device	Package Type	Package Drawing	Pins	SPQ	Reel Diameter (mm)	Reel Width W1 (mm)	A0 (mm)	B0 (mm)	K0 (mm)	P1 (mm)	W (mm)	Pin1 Quadrant
BQ27501DRZR	SON	DRZ	12	3000	330.0	12.4	2.8	4.3	1.2	4.0	12.0	Q2
BQ27501DRZT	SON	DRZ	12	250	330.0	12.4	2.8	4.3	1.2	4.0	12.0	Q2

TAPE AND REEL BOX DIMENSIONS

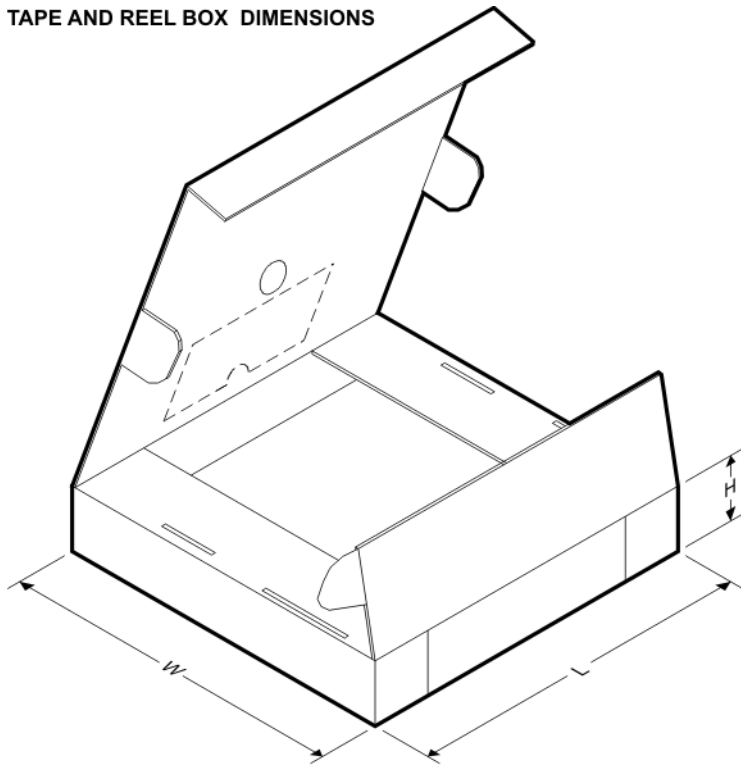

\*All dimensions are nominal

Device	Package Type	Package Drawing	Pins	SPQ	Length (mm)	Width (mm)	Height (mm)
BQ27501DRZR	SON	DRZ	12	3000	340.5	333.0	20.6
BQ27501DRZT	SON	DRZ	12	250	340.5	333.0	20.6

DRZ (S-PDSO-N12)

PLASTIC SMALL OUTLINE

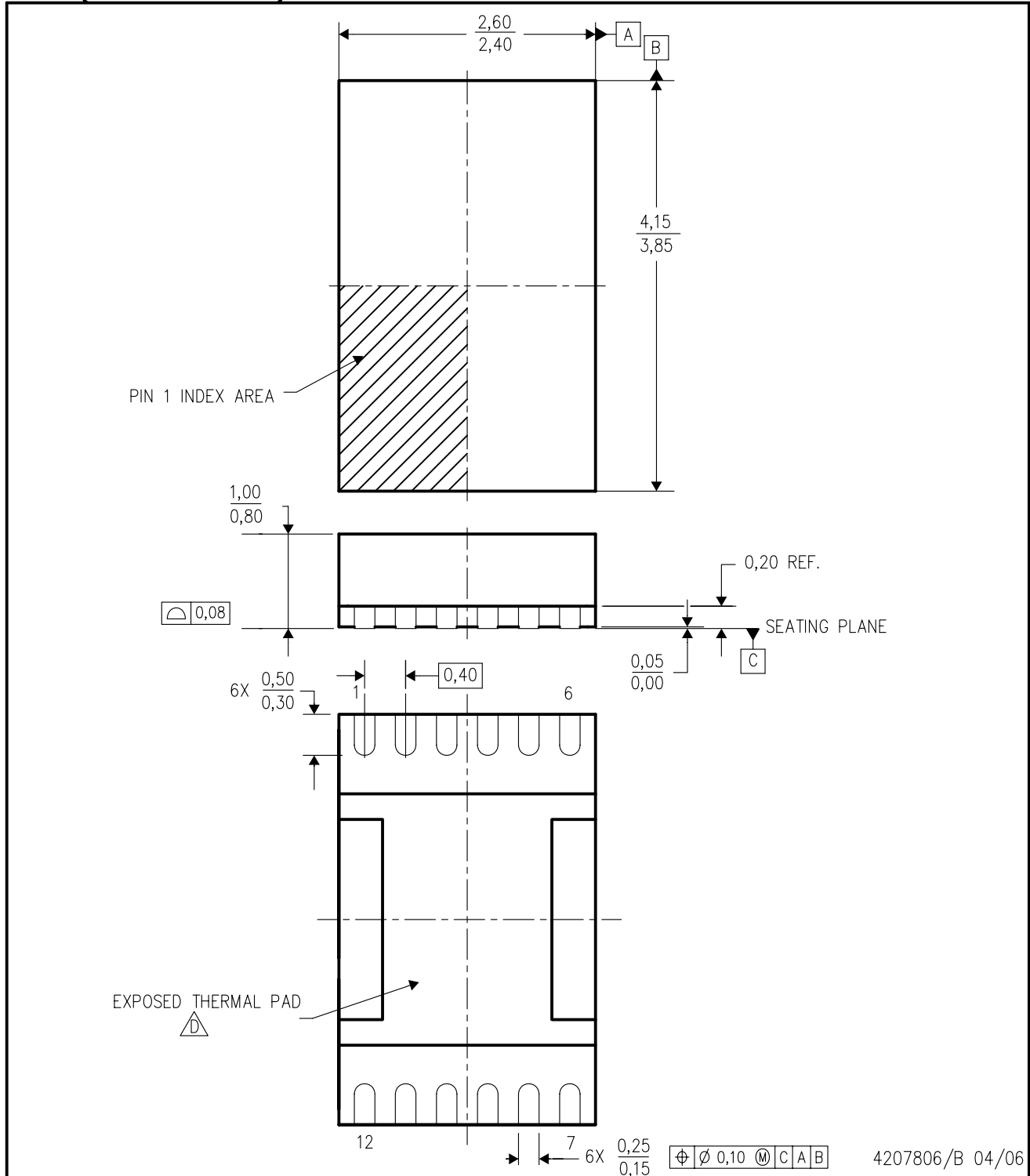

- NOTES:
- A. All linear dimensions are in millimeters. Dimensioning and tolerancing per ASME Y14.5M-1994.
  - B. This drawing is subject to change without notice.
  - C. Small Outline No-Lead (SON) package configuration.
  - D. The package thermal pad must be soldered to the board for thermal and mechanical performance. See the Product Data Sheet for details regarding the exposed thermal pad dimensions.
  - E. This package is lead-free.

## THERMAL PAD MECHANICAL DATA

DRZ (R-PDSO-N12)

PLASTIC SMALL OUTLINE NO-LEAD

### THERMAL INFORMATION

This package incorporates an exposed thermal pad that is designed to be attached directly to an external heatsink. The thermal pad must be soldered directly to the printed circuit board (PCB). After soldering, the PCB can be used as a heatsink. In addition, through the use of thermal vias, the thermal pad can be attached directly to the appropriate copper plane shown in the electrical schematic for the device, or alternatively, can be attached to a special heatsink structure designed into the PCB. This design optimizes the heat transfer from the integrated circuit (IC).

For information on the Quad Flatpack No-Lead (QFN) package and its advantages, refer to Application Report, QFN/SON PCB Attachment, Texas Instruments Literature No. SLUA271. This document is available at [www.ti.com](http://www.ti.com).

The exposed thermal pad dimensions for this package are shown in the following illustration.

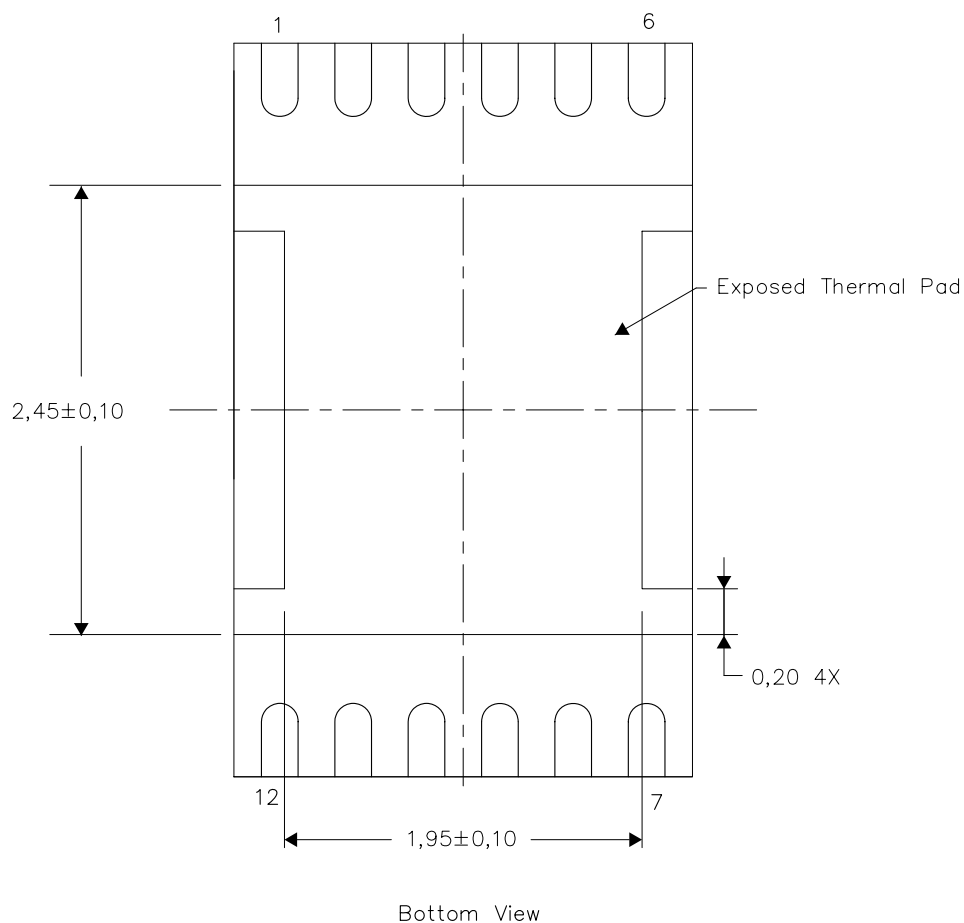

NOTE: All linear dimensions are in millimeters

Exposed Thermal Pad Dimensions

4208114/E 06/10

DRZ (S-PDSO-N12)

PLASTIC SMALL OUTLINE NO-LEAD

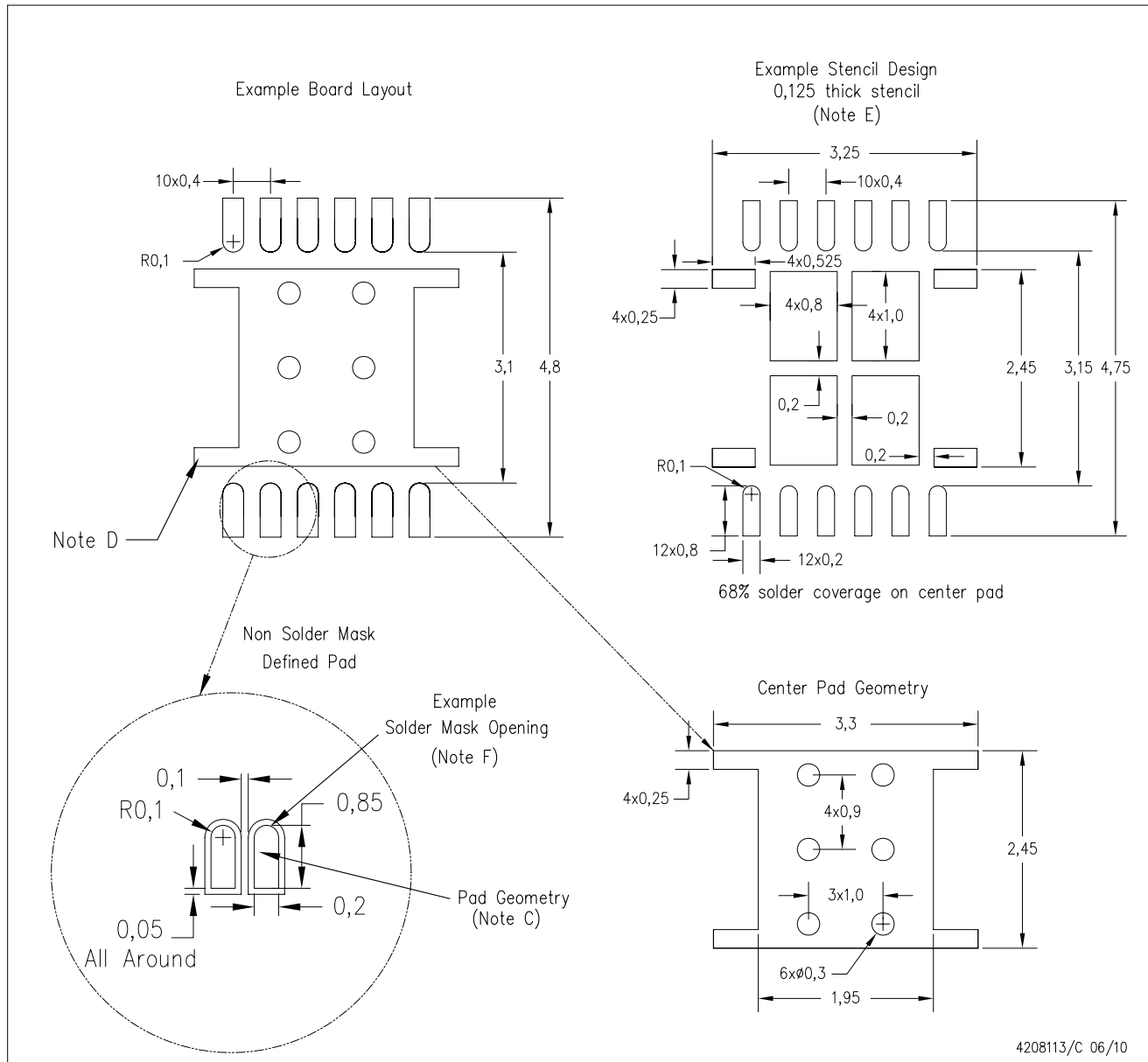

- NOTES:
- All linear dimensions are in millimeters.
  - This drawing is subject to change without notice.
  - Publication IPC-7351 is recommended for alternate designs.
  - This package is designed to be soldered to a thermal pad on the board. Refer to Application Note, Quad Flat-Pack Packages, Texas Instruments Literature No. SCBA017, SLUA271, and also the Product Data Sheets for specific thermal information, via requirements, and recommended board layout. These documents are available at [www.ti.com](http://www.ti.com) <<http://www.ti.com>>.
  - Laser cutting apertures with trapezoidal walls and also rounding corners will offer better paste release. Customers should contact their board assembly site for stencil design recommendations. Refer to IPC 7525 for stencil design considerations.
  - Customers should contact their board fabrication site for minimum solder mask web tolerances between signal pads.

## IMPORTANT NOTICE

Texas Instruments Incorporated and its subsidiaries (TI) reserve the right to make corrections, modifications, enhancements, improvements, and other changes to its products and services at any time and to discontinue any product or service without notice. Customers should obtain the latest relevant information before placing orders and should verify that such information is current and complete. All products are sold subject to TI's terms and conditions of sale supplied at the time of order acknowledgment.

TI warrants performance of its hardware products to the specifications applicable at the time of sale in accordance with TI's standard warranty. Testing and other quality control techniques are used to the extent TI deems necessary to support this warranty. Except where mandated by government requirements, testing of all parameters of each product is not necessarily performed.

TI assumes no liability for applications assistance or customer product design. Customers are responsible for their products and applications using TI components. To minimize the risks associated with customer products and applications, customers should provide adequate design and operating safeguards.

TI does not warrant or represent that any license, either express or implied, is granted under any TI patent right, copyright, mask work right, or other TI intellectual property right relating to any combination, machine, or process in which TI products or services are used. Information published by TI regarding third-party products or services does not constitute a license from TI to use such products or services or a warranty or endorsement thereof. Use of such information may require a license from a third party under the patents or other intellectual property of the third party, or a license from TI under the patents or other intellectual property of TI.

Reproduction of TI information in TI data books or data sheets is permissible only if reproduction is without alteration and is accompanied by all associated warranties, conditions, limitations, and notices. Reproduction of this information with alteration is an unfair and deceptive business practice. TI is not responsible or liable for such altered documentation. Information of third parties may be subject to additional restrictions.

Resale of TI products or services with statements different from or beyond the parameters stated by TI for that product or service voids all express and any implied warranties for the associated TI product or service and is an unfair and deceptive business practice. TI is not responsible or liable for any such statements.

TI products are not authorized for use in safety-critical applications (such as life support) where a failure of the TI product would reasonably be expected to cause severe personal injury or death, unless officers of the parties have executed an agreement specifically governing such use. Buyers represent that they have all necessary expertise in the safety and regulatory ramifications of their applications, and acknowledge and agree that they are solely responsible for all legal, regulatory and safety-related requirements concerning their products and any use of TI products in such safety-critical applications, notwithstanding any applications-related information or support that may be provided by TI. Further, Buyers must fully indemnify TI and its representatives against any damages arising out of the use of TI products in such safety-critical applications.

TI products are neither designed nor intended for use in military/aerospace applications or environments unless the TI products are specifically designated by TI as military-grade or "enhanced plastic." Only products designated by TI as military-grade meet military specifications. Buyers acknowledge and agree that any such use of TI products which TI has not designated as military-grade is solely at the Buyer's risk, and that they are solely responsible for compliance with all legal and regulatory requirements in connection with such use.

TI products are neither designed nor intended for use in automotive applications or environments unless the specific TI products are designated by TI as compliant with ISO/TS 16949 requirements. Buyers acknowledge and agree that, if they use any non-designated products in automotive applications, TI will not be responsible for any failure to meet such requirements.

Following are URLs where you can obtain information on other Texas Instruments products and application solutions:

<b>Products</b>		<b>Applications</b>	
Amplifiers	<a href="http://amplifier.ti.com">amplifier.ti.com</a>	Audio	<a href="http://www.ti.com/audio">www.ti.com/audio</a>
Data Converters	<a href="http://dataconverter.ti.com">dataconverter.ti.com</a>	Automotive	<a href="http://www.ti.com/automotive">www.ti.com/automotive</a>
DLP® Products	<a href="http://www.dlp.com">www.dlp.com</a>	Communications and Telecom	<a href="http://www.ti.com/communications">www.ti.com/communications</a>
DSP	<a href="http://dsp.ti.com">dsp.ti.com</a>	Computers and Peripherals	<a href="http://www.ti.com/computers">www.ti.com/computers</a>
Clocks and Timers	<a href="http://www.ti.com/clocks">www.ti.com/clocks</a>	Consumer Electronics	<a href="http://www.ti.com/consumer-apps">www.ti.com/consumer-apps</a>
Interface	<a href="http://interface.ti.com">interface.ti.com</a>	Energy	<a href="http://www.ti.com/energy">www.ti.com/energy</a>
Logic	<a href="http://logic.ti.com">logic.ti.com</a>	Industrial	<a href="http://www.ti.com/industrial">www.ti.com/industrial</a>
Power Mgmt	<a href="http://power.ti.com">power.ti.com</a>	Medical	<a href="http://www.ti.com/medical">www.ti.com/medical</a>
Microcontrollers	<a href="http://microcontroller.ti.com">microcontroller.ti.com</a>	Security	<a href="http://www.ti.com/security">www.ti.com/security</a>
RFID	<a href="http://www.ti-rfid.com">www.ti-rfid.com</a>	Space, Avionics & Defense	<a href="http://www.ti.com/space-avionics-defense">www.ti.com/space-avionics-defense</a>
RF/IF and ZigBee® Solutions	<a href="http://www.ti.com/lprf">www.ti.com/lprf</a>	Video and Imaging	<a href="http://www.ti.com/video">www.ti.com/video</a>
		Wireless	<a href="http://www.ti.com/wireless-apps">www.ti.com/wireless-apps</a>

Mailing Address: Texas Instruments, Post Office Box 655303, Dallas, Texas 75265  
Copyright © 2010, Texas Instruments Incorporated